

# Graph Theory

## Part One

But first...

# Midterm Exam Logistics

- Our first midterm exam is next ***Tuesday, April 28th***, from ***7:00 - 9:00 PM***.
- DO bring a photo ID.
- DO bring one sheet 8.5"x11" (both sides) of notes.
- DON'T bring a backpack, bag, etc if you can possibly avoid it. If you do bring one, it will need to be left at the front of the room, and there usually isn't enough space up there for more than a few students to do this. So it's easier if you can leave those items at home.

# Midterm Exam

- ***We want you to do well on this exam!***
  - We're not trying to enforce a curve where there isn't one.
  - Our philosophy is:
    - Communicate clearly what we want you to know
    - Teach you that stuff and reinforce in several ways (lecture, pset), emphasis proportional to our priorities
    - Test you what we said we would teach you, with emphasis proportional to emphasis in lectures, psets
    - In other words: no “surprises”
- The purpose of this midterm is to give you a chance to show what you've learned in the past few weeks, and see where you can improve for Midterm 2 and Final.

# Preparing for the Exam

- We've posted an ***Exam Logistics*** page on the course website with full details and logistics.
- It also includes advice from former CS103 students about how to do well on the exam.

# Outline for Today

- ***Graphs and Digraphs***
  - Two fundamental mathematical structures.
- ***Independent Sets and Vertex Covers***
  - Two structures in graphs.
- ***Proofs on Graphs***
  - Reprising themes from last week.

# Graphs: An Overview

A ***graph*** is a mathematical structure for representing relationships.

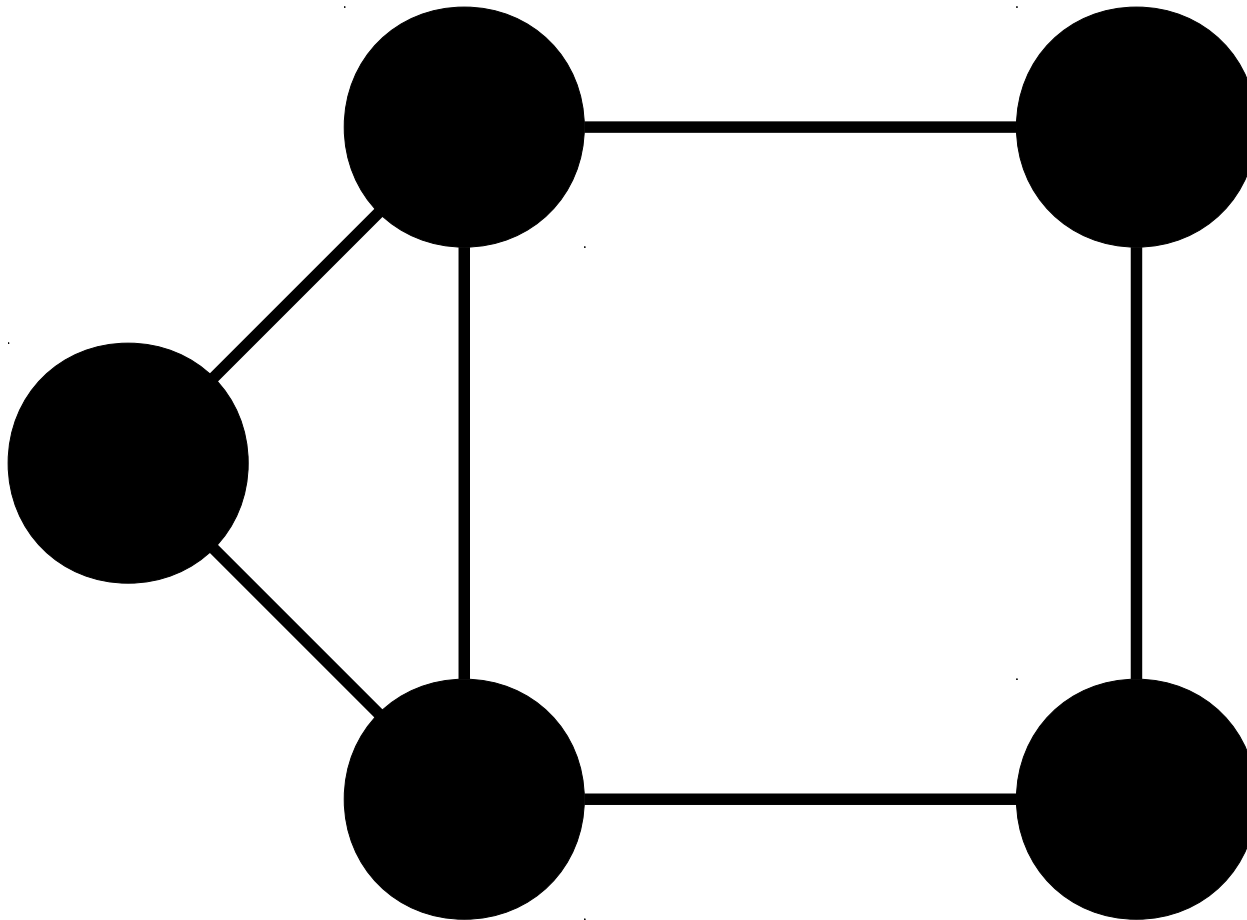

A **graph** is a mathematical structure for representing relationships.

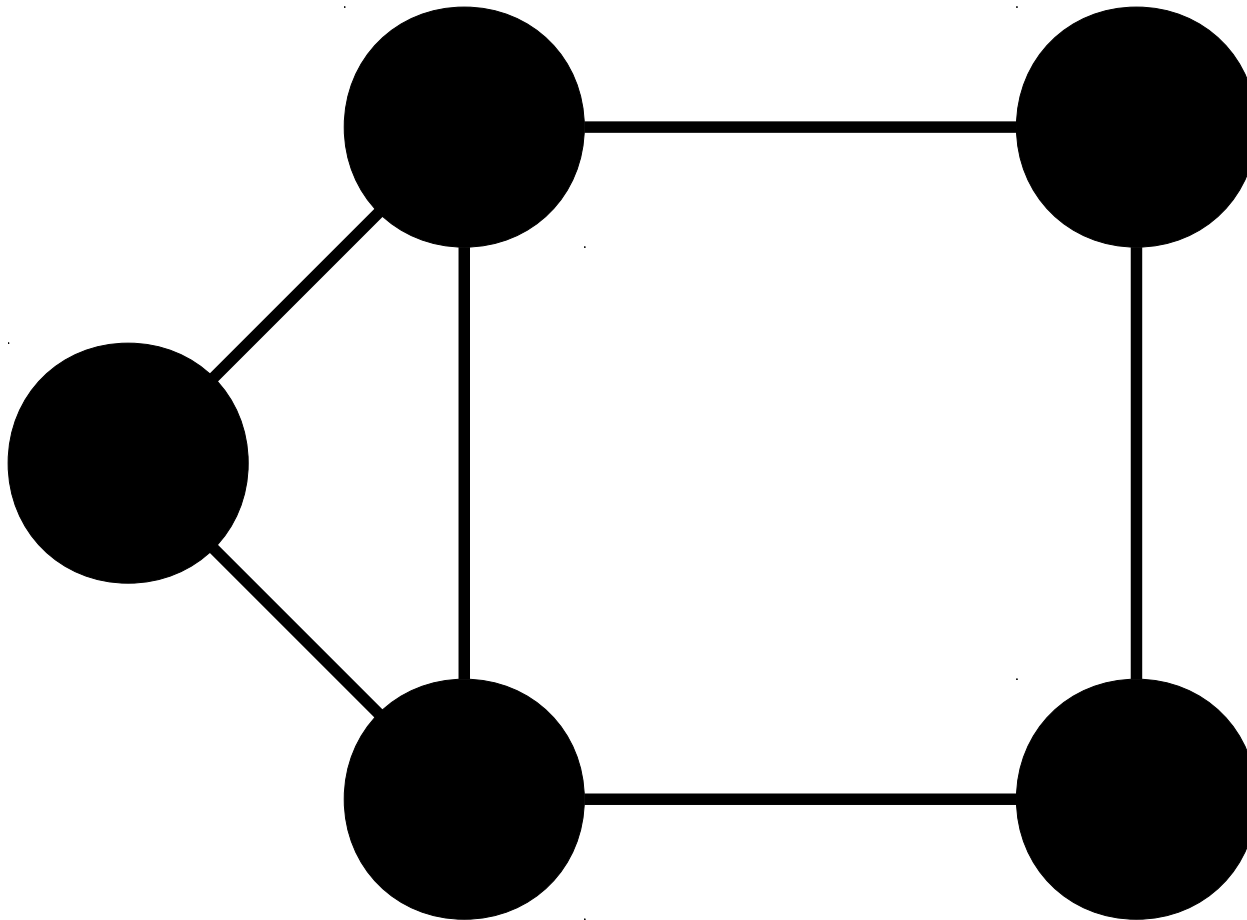

A graph consists of a set of **nodes** (or **vertices**) connected by **edges** (or **arcs**)

A **graph** is a mathematical structure for representing relationships.

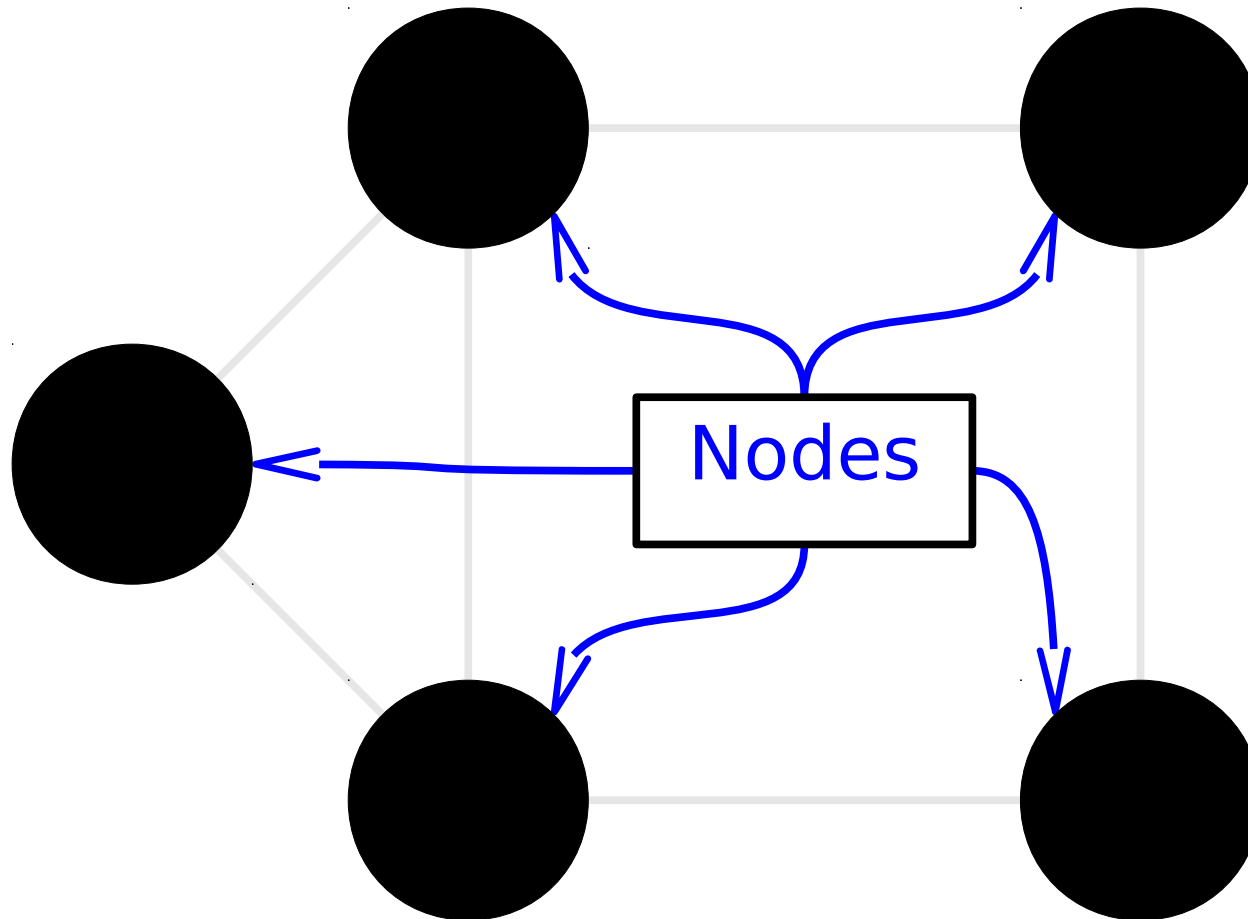

A graph consists of a set of **nodes** (or **vertices**) connected by **edges** (or **arcs**)

A **graph** is a mathematical structure for representing relationships.

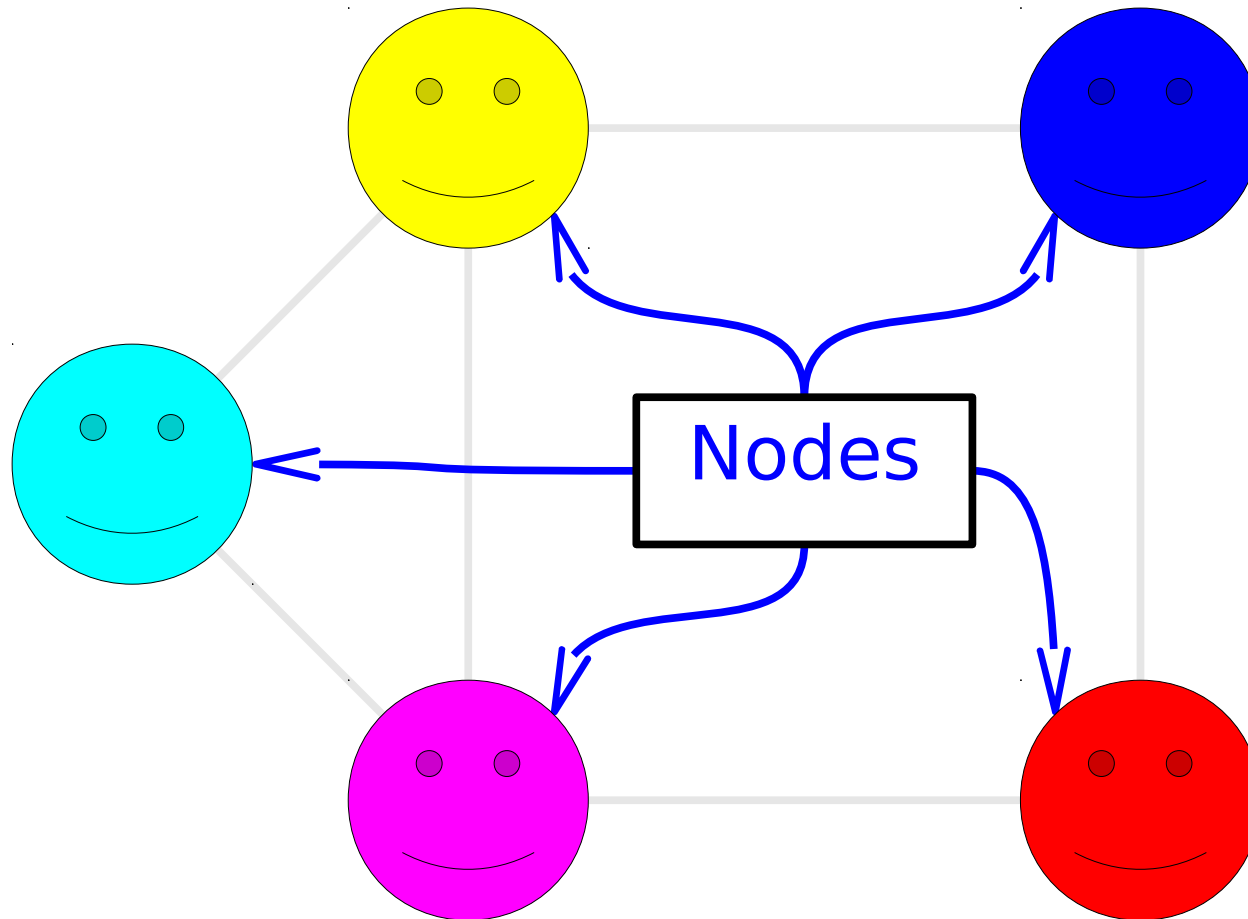

A graph consists of a set of **nodes** (or **vertices**) connected by **edges** (or **arcs**)

A **graph** is a mathematical structure for representing relationships.

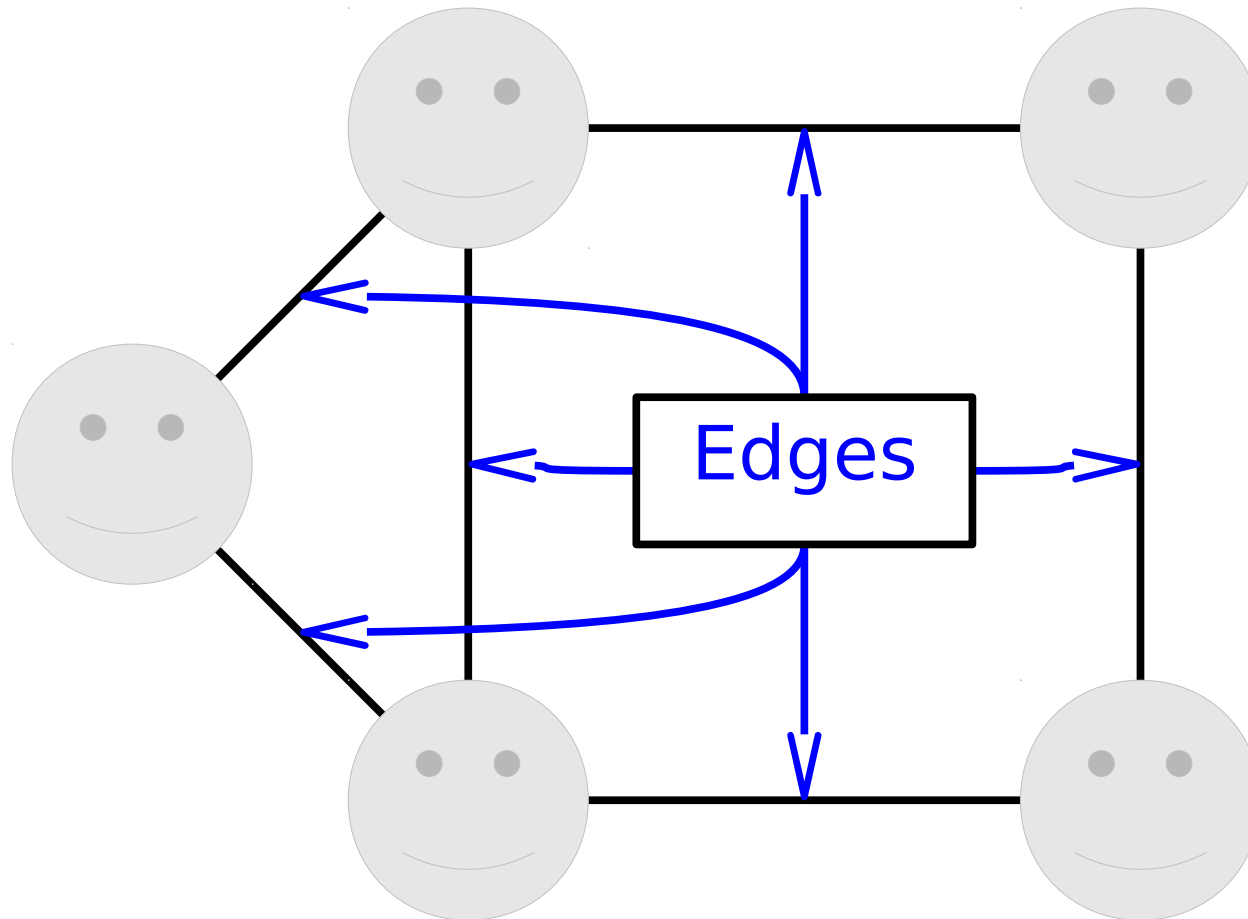

A graph consists of a set of **nodes** (or **vertices**) connected by **edges** (or **arcs**)

A **graph** is a mathematical structure for representing relationships.

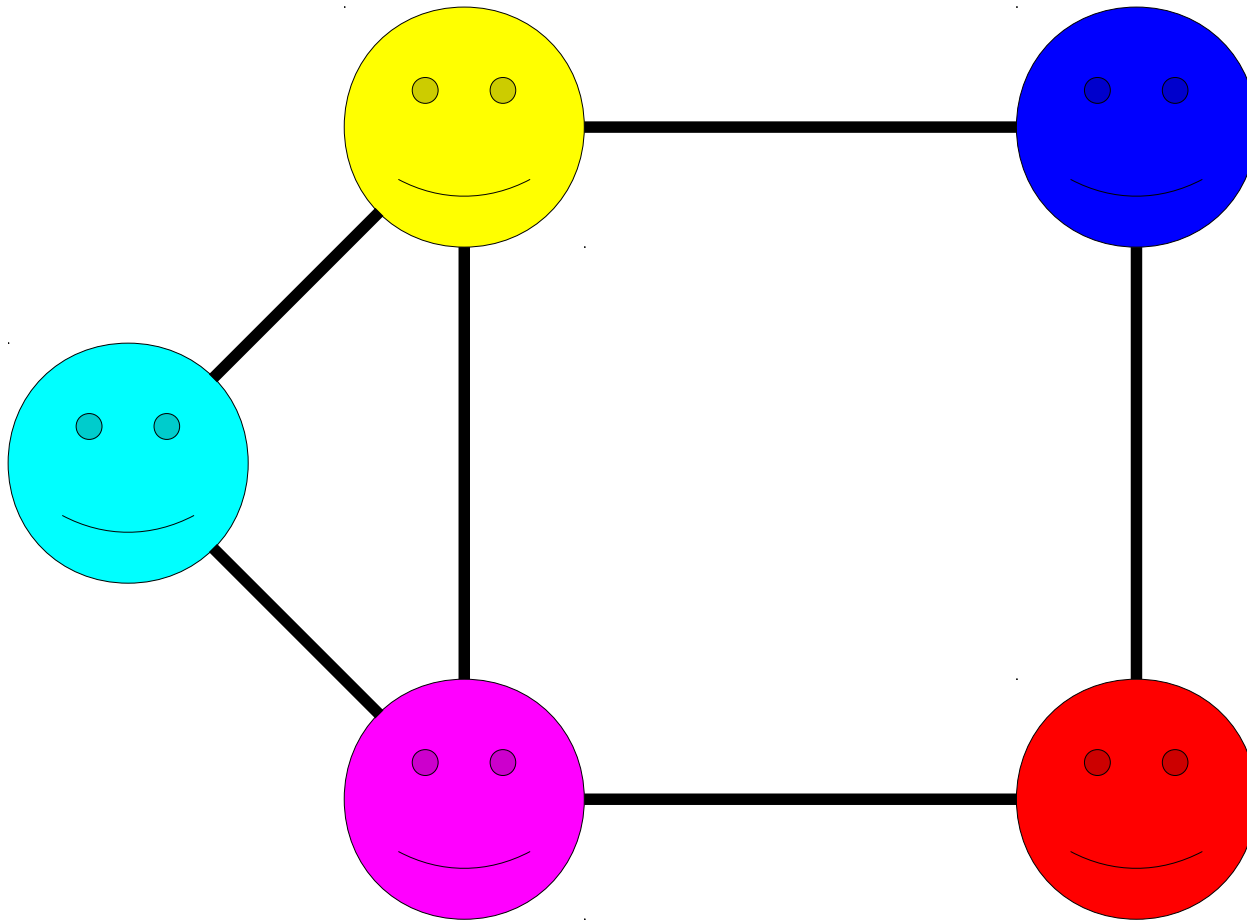

A graph consists of a set of **nodes** (or **vertices**) connected by **edges** (or **arcs**)

# Examples

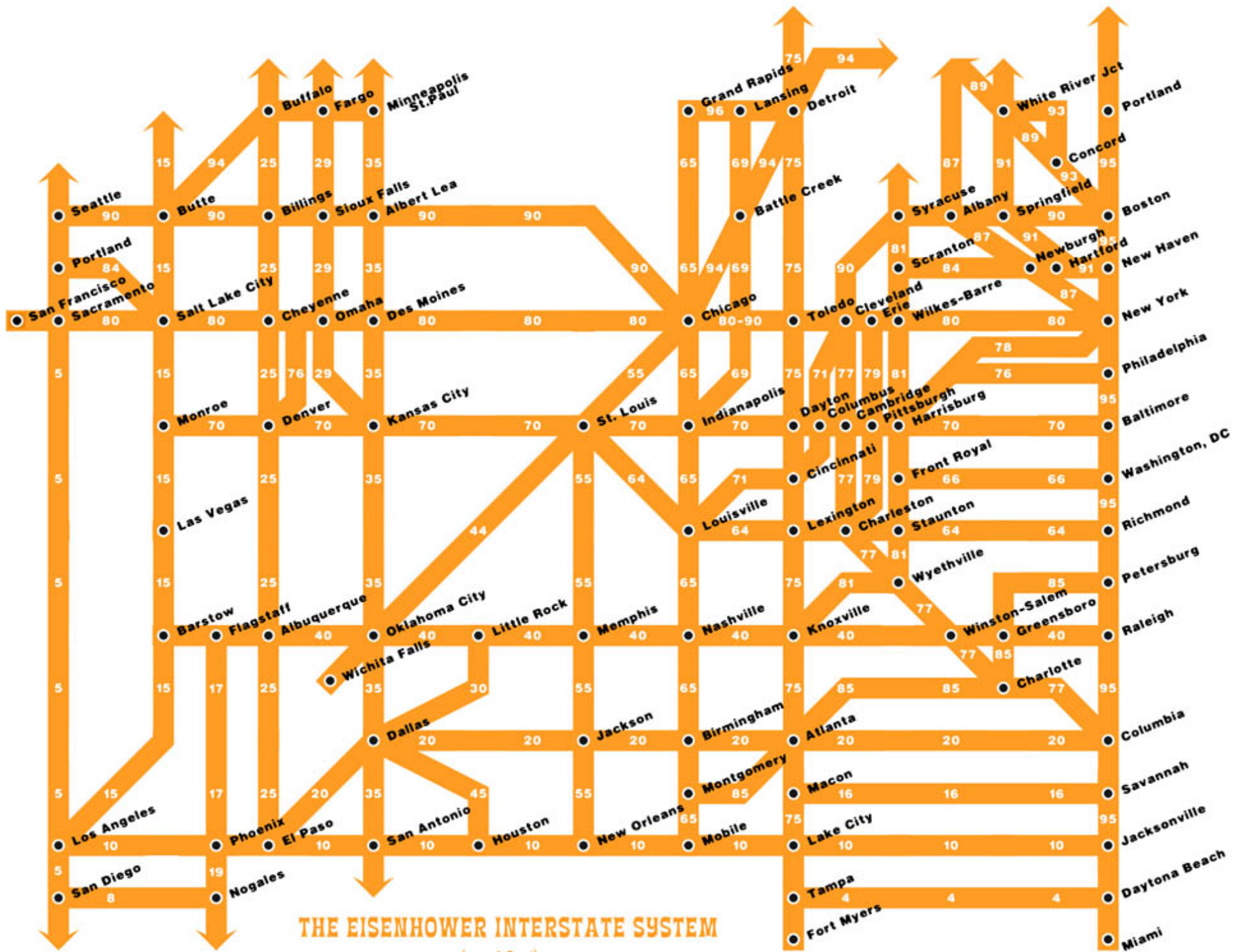

**THE EISENHOWER INTERSTATE SYSTEM**

(simplified)







WeChat

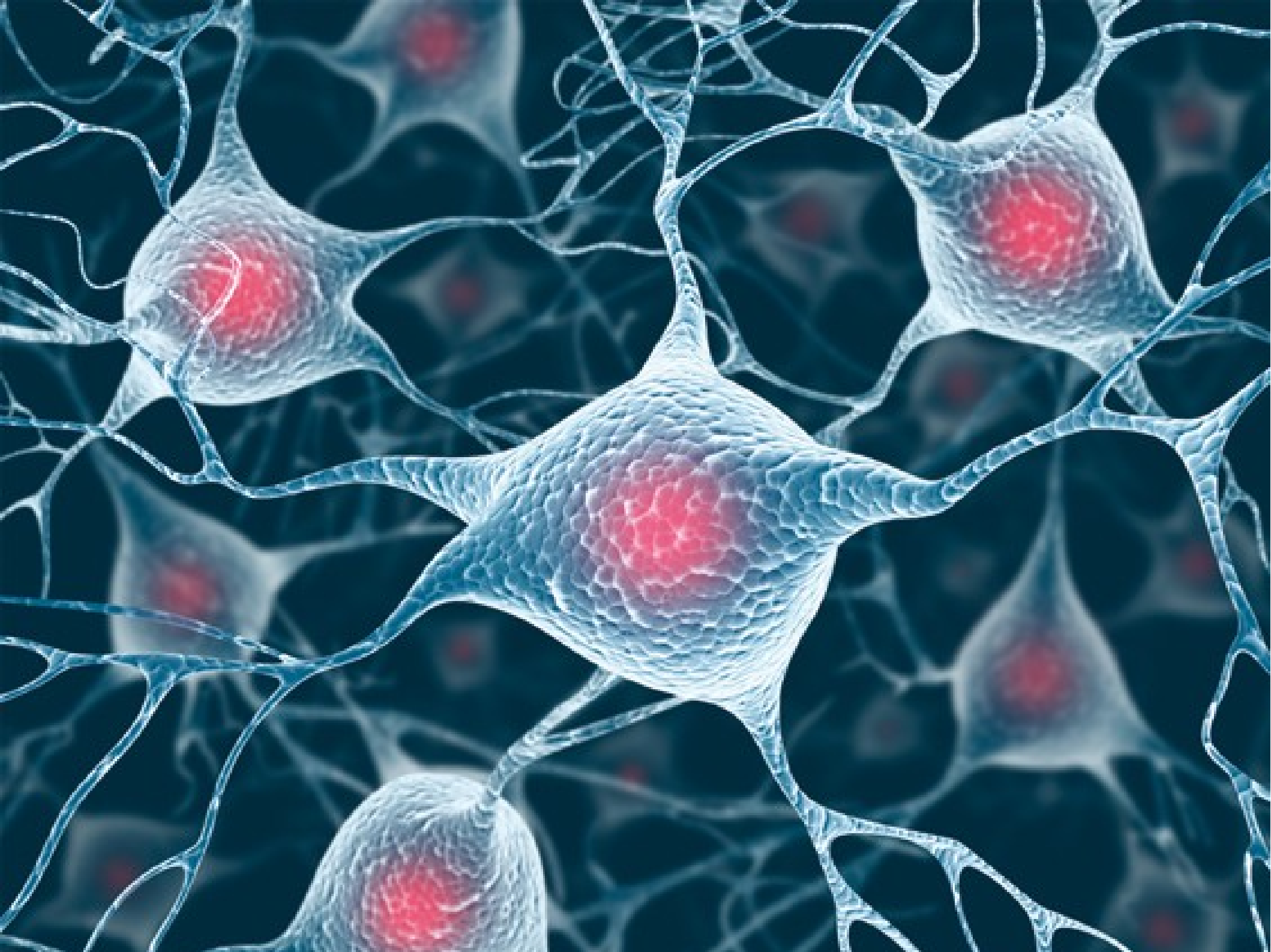

# What's in Common

- Each of these structures consists of
  - a collection of objects and
  - links between those objects.
- **Goal:** Develop a general framework for describing structures like these that generalizes the idea across many domains.

# Graphs vs. Digraphs

A **graph** is a mathematical structure for representing relationships.

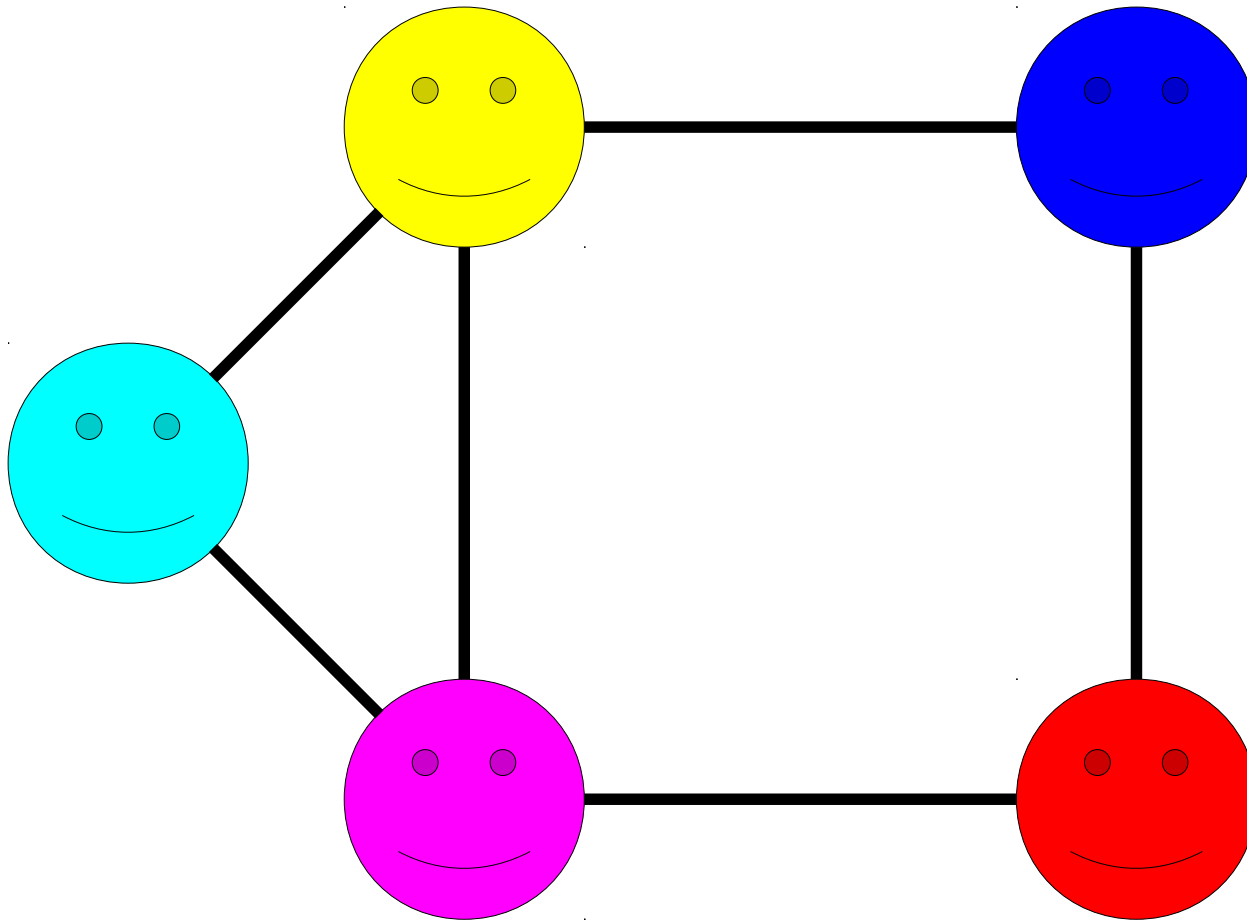

A graph consists of a set of **nodes** (or **vertices**) connected by **edges** (or **arcs**)

Some graphs are *directed*.

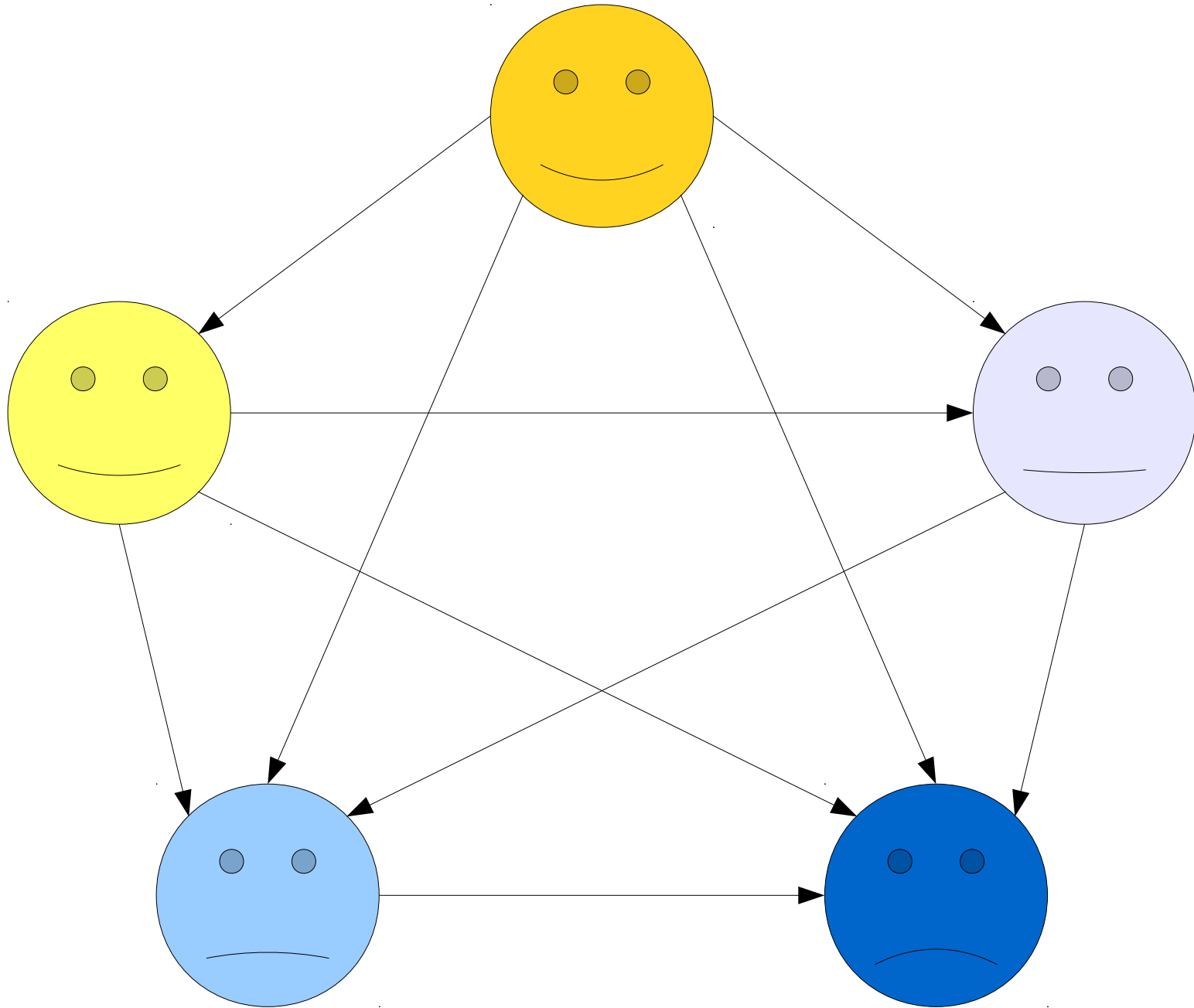

Some graphs are *undirected*.

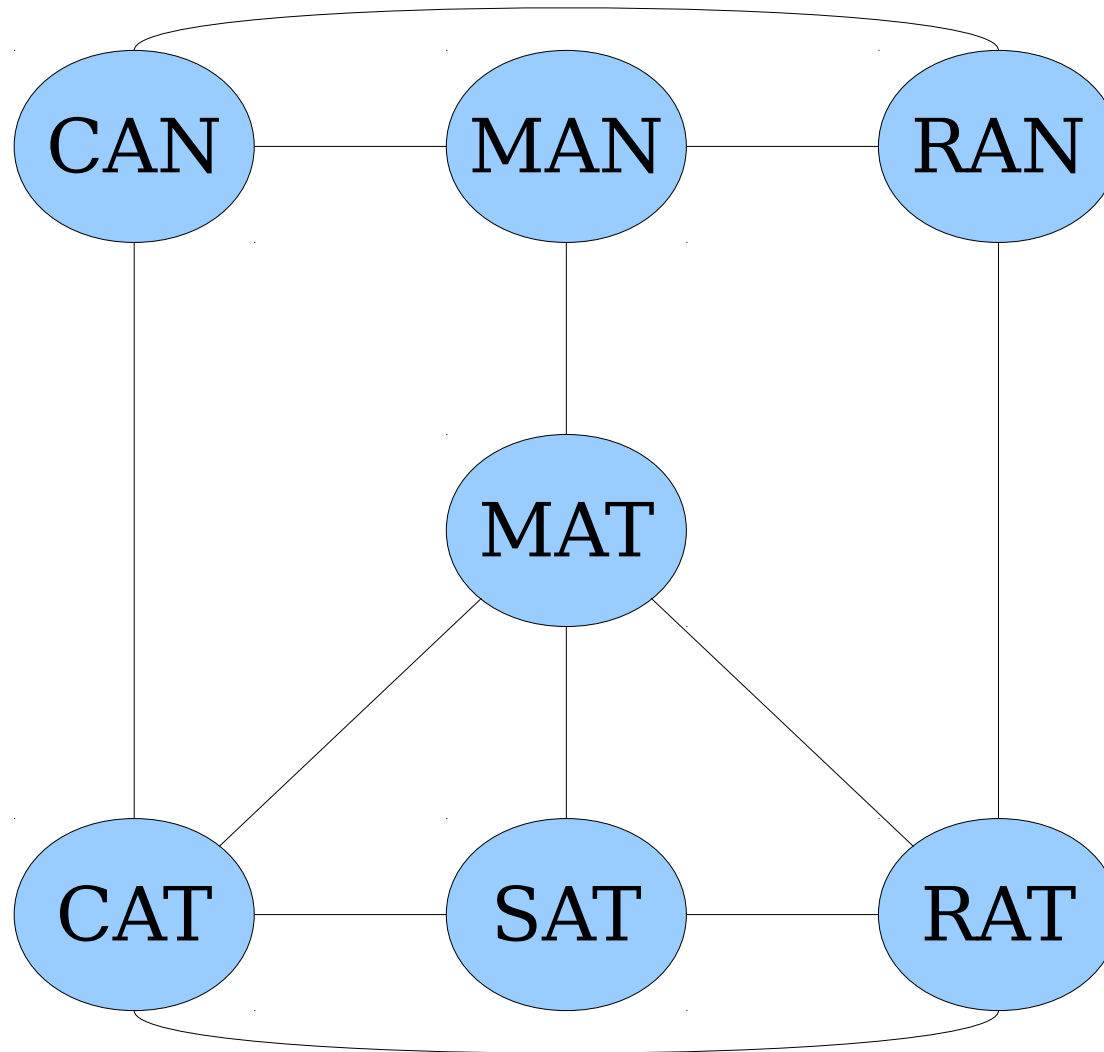

# Graphs and Digraphs

- An ***undirected graph*** is one where edges link nodes, with no endpoint preferred over the other.
- A ***directed graph*** (or ***digraph***) is one where edges have an associated direction.
  - (There's something called a ***mixed graph*** that allows for both types of edges, but they're fairly uncommon and we won't talk about them.)
- Unless specified otherwise:

👉 ***“Graph” means “undirected graph”*** 👈

# Formalizing Graphs

- How might we define a graph mathematically?
- We need to specify
  - what the nodes in the graph are, and
  - which edges are in the graph.
- The nodes can be pretty much anything.
- What about edges?

# Formalizing Graphs

- An ***unordered pair*** is a set  $\{a, b\}$  of two elements  $a \neq b$ . (Remember that sets are unordered.)
  - For example,  $\{0, 1\} = \{1, 0\}$
- An ***undirected graph*** is an ordered pair  $G = (V, E)$ , where
  - $V$  is a set of nodes, which can be anything, and
  - $E$  is a set of edges, which are *unordered* pairs of nodes drawn from  $V$ .
- A ***directed graph*** (or ***digraph***) is an ordered pair  $G = (V, E)$ , where
  - $V$  is a set of nodes, which can be anything, and
  - $E$  is a set of edges, which are *ordered* pairs of nodes drawn from  $V$ .

Which of the following are valid undirected graphs?

1

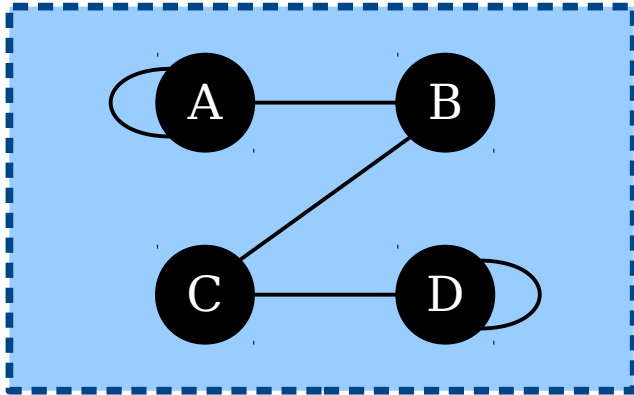

2

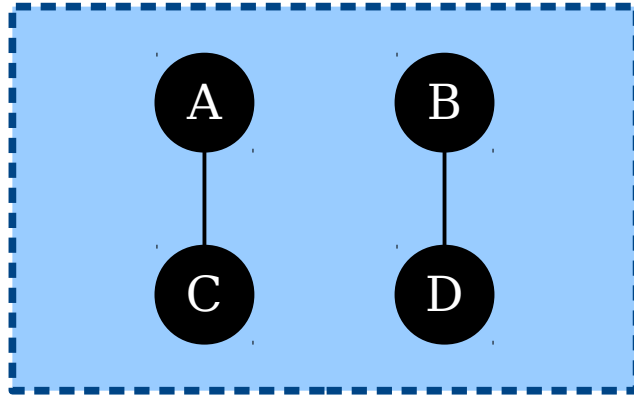

3

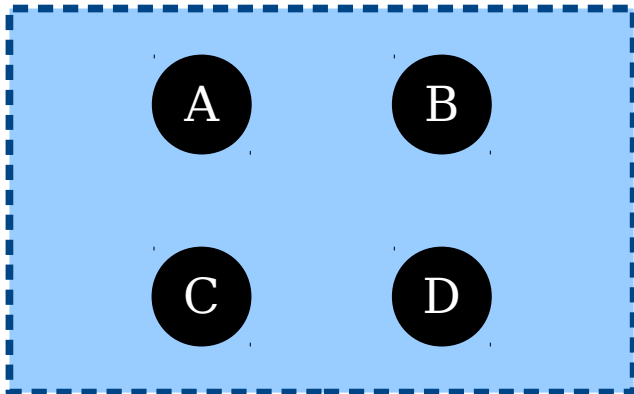

4

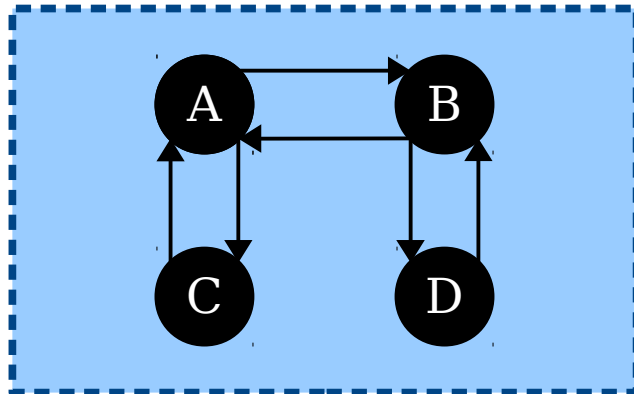

PollEv.com/  
cs103spr26



# Self-Loops

- An edge from a node to itself is called a ***self-loop***.
- In (undirected) graphs, self-loops are generally not allowed.
  - Can you see how this follows from the definition?

- In digraphs, self-loops are generally allowed unless specified otherwise.

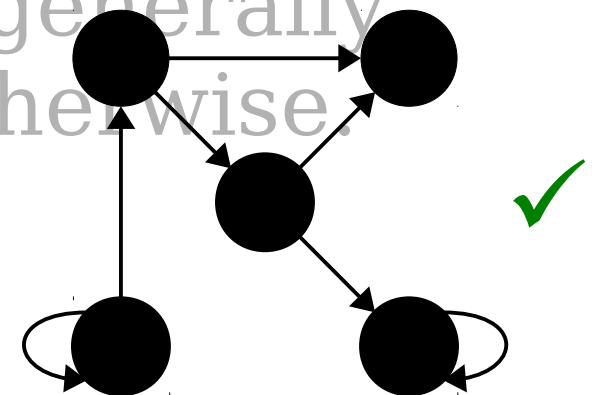
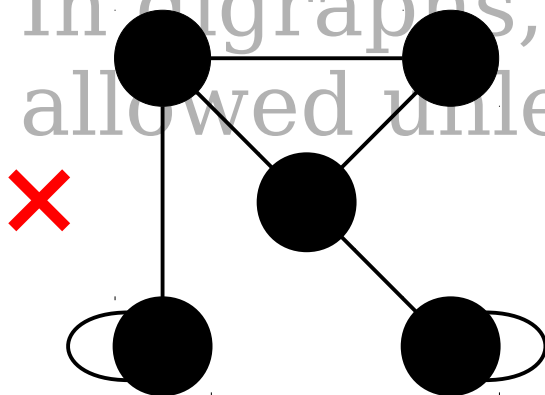

# Independent Sets and Vertex Covers

# Two Motivating Problems

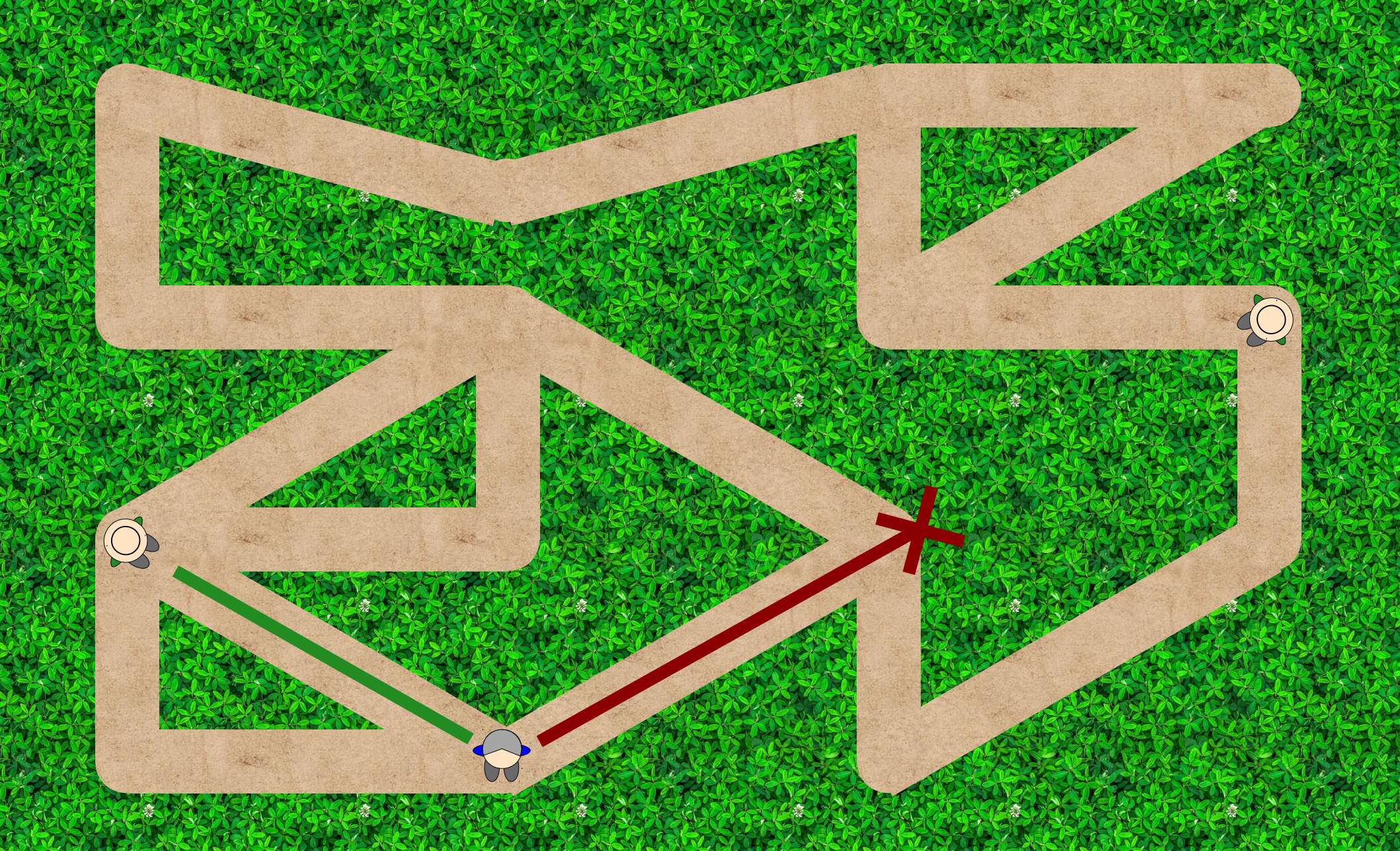

Place park rangers in these forest trails so that a hiker anywhere on a trail can see a park ranger.

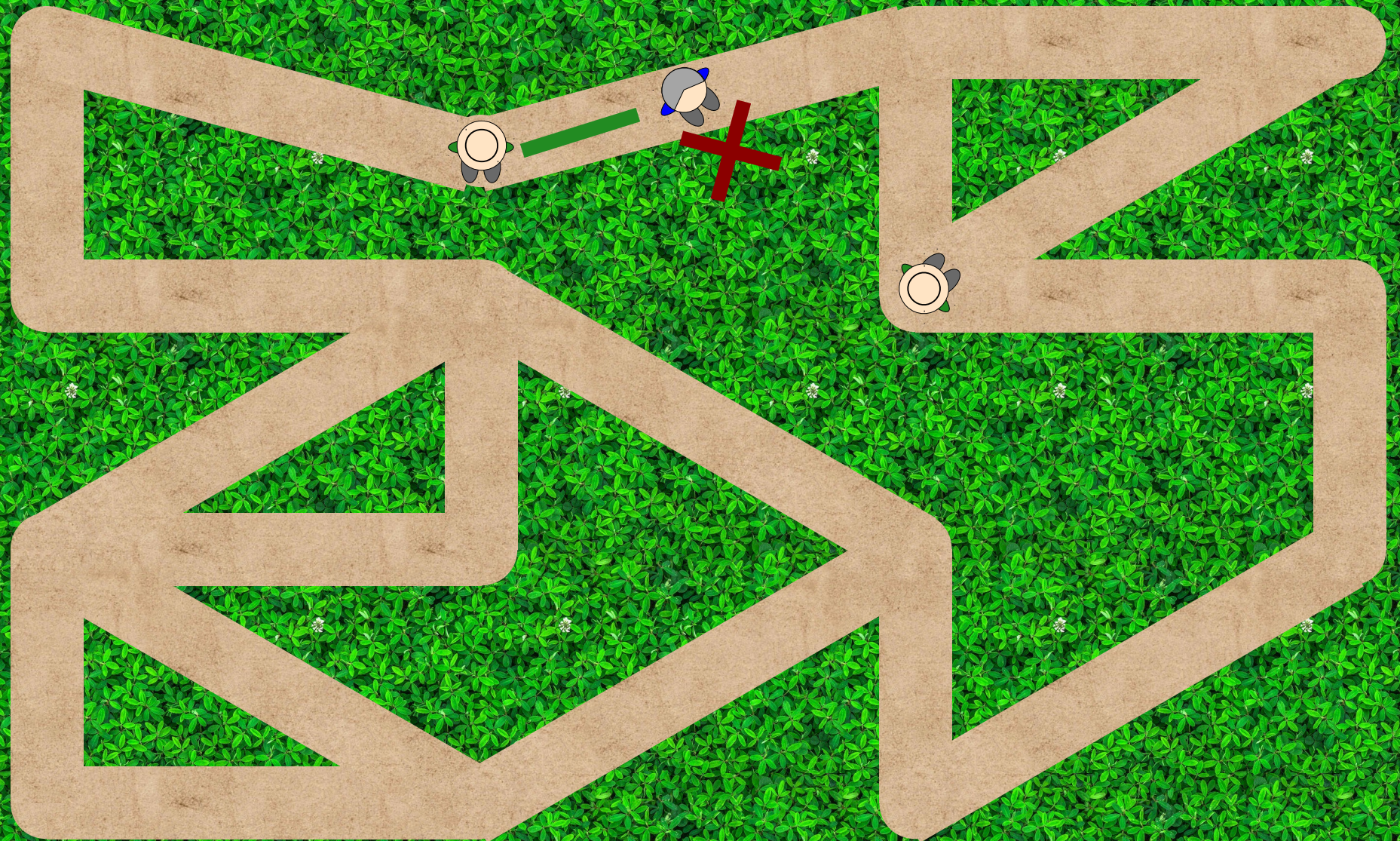

Place park rangers in these forest trails so that a hiker anywhere on a trail can see a park ranger.

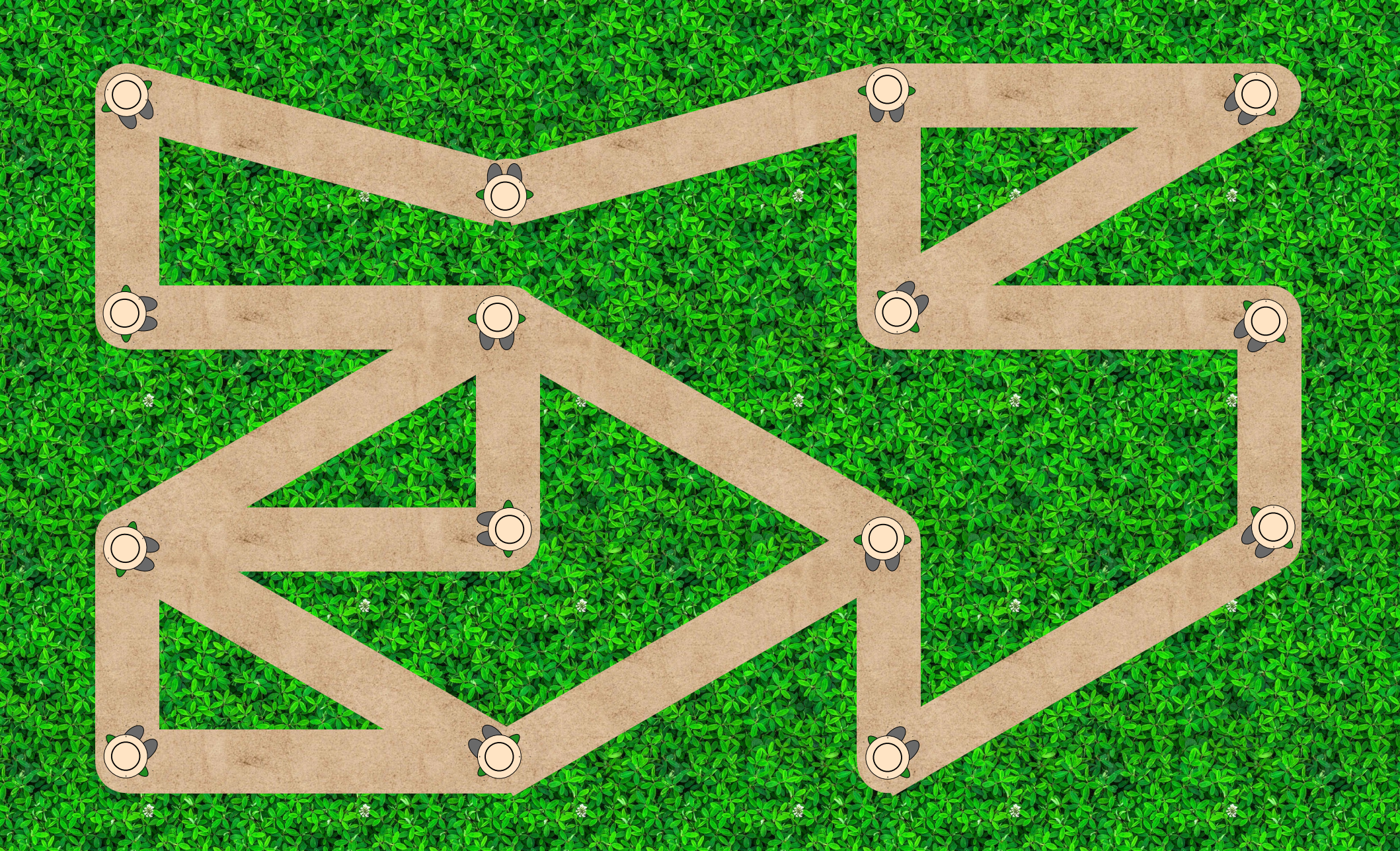

Place park rangers in these forest trails so that a hiker anywhere on a trail can see a park ranger.

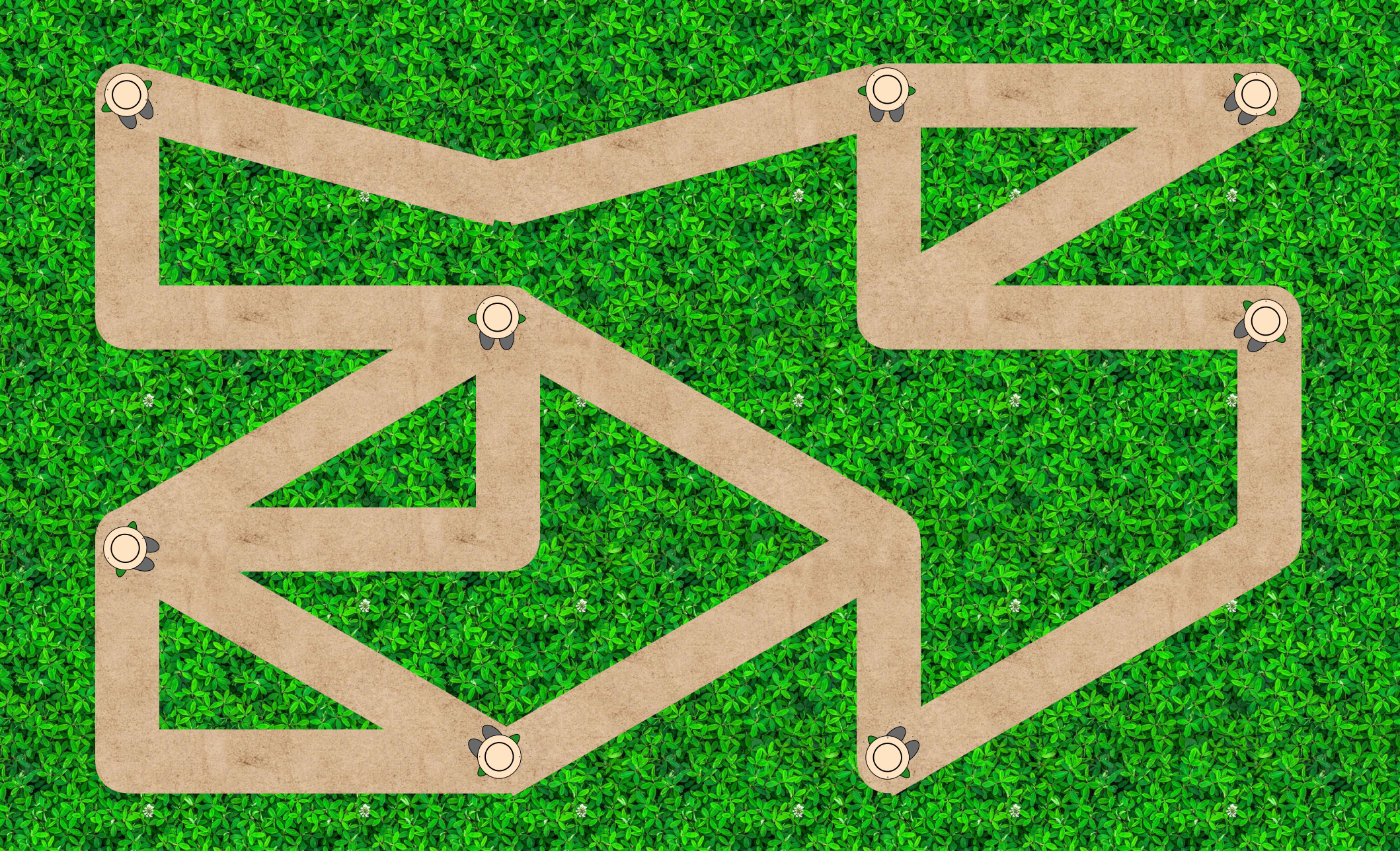

Place park rangers in these forest trails so that a hiker anywhere on a trail can see a park ranger.

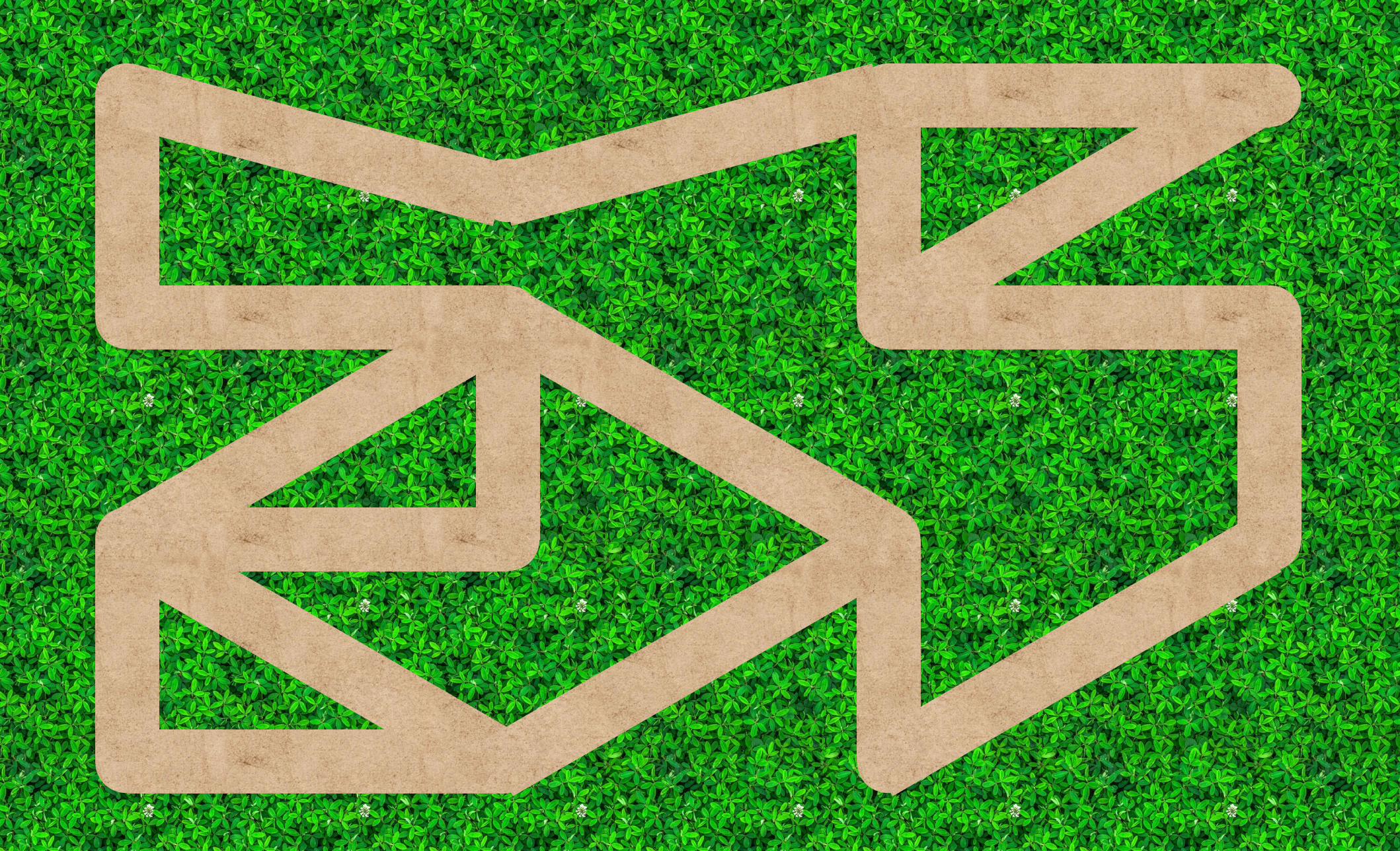

Place park rangers in these forest trails so that a hiker anywhere on a trail can see a park ranger.

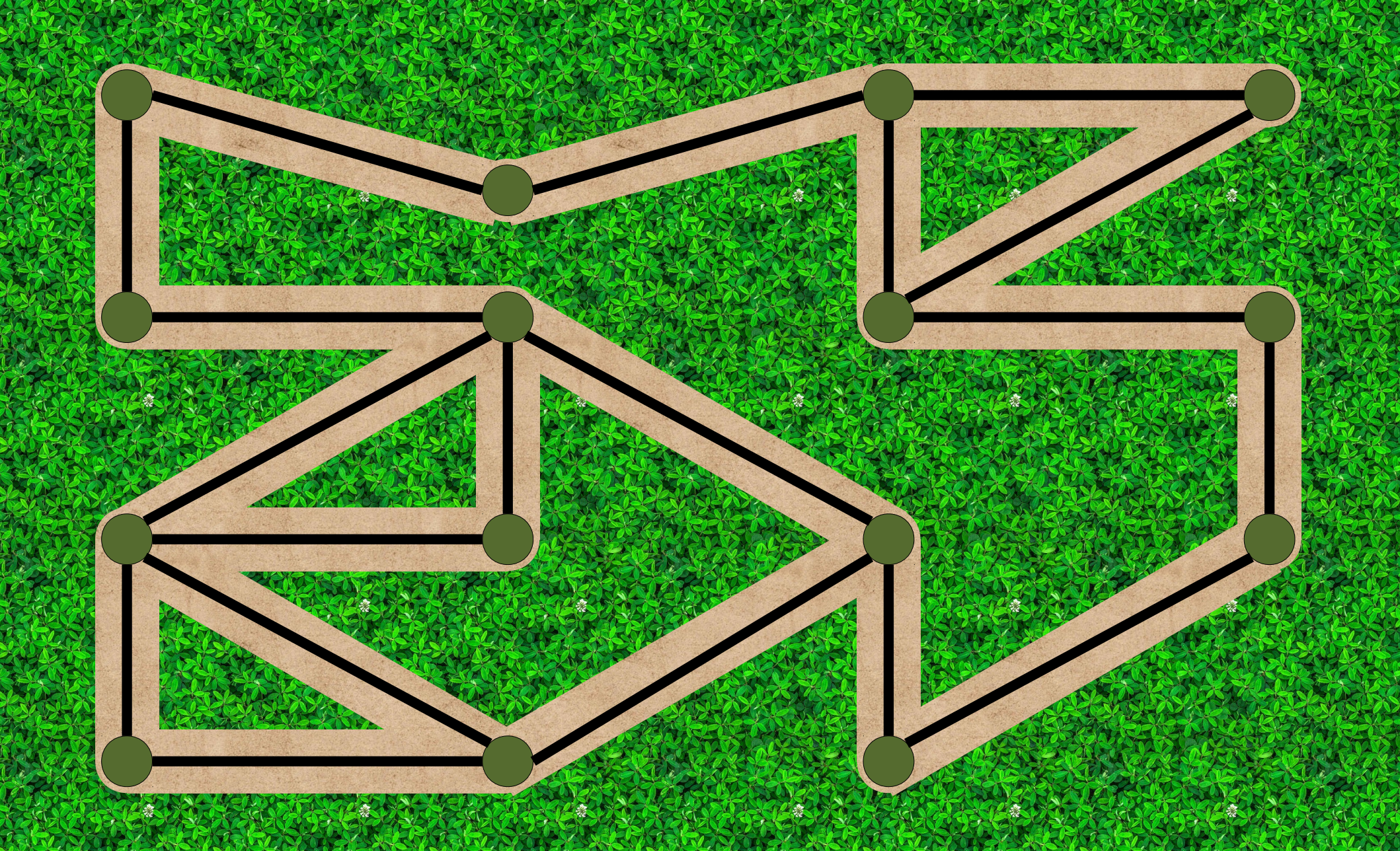

Place park rangers in these forest trails so that a hiker anywhere on a trail can see a park ranger.

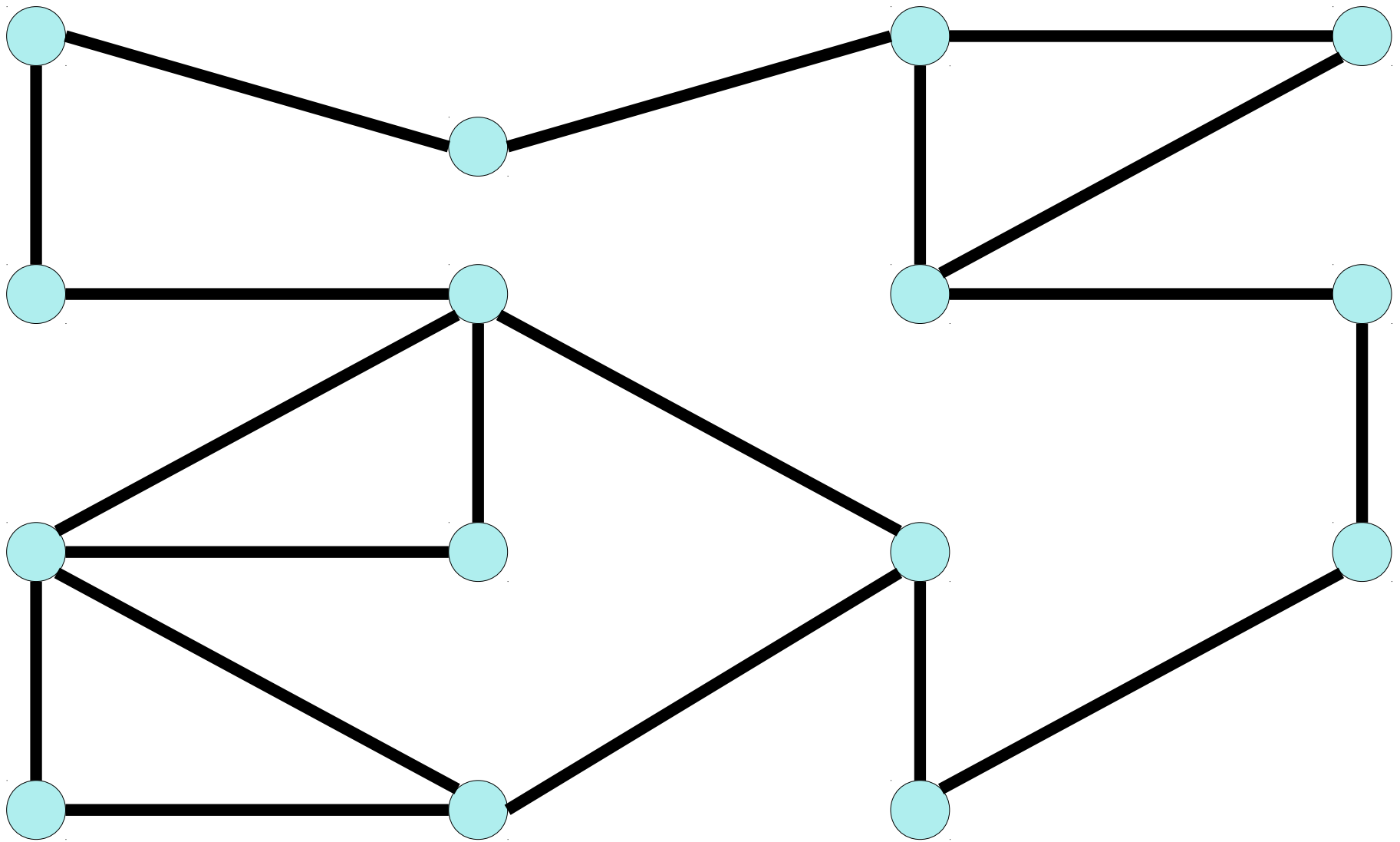

---

Place park rangers in these forest trails so that a hiker anywhere on a trail can see a park ranger.





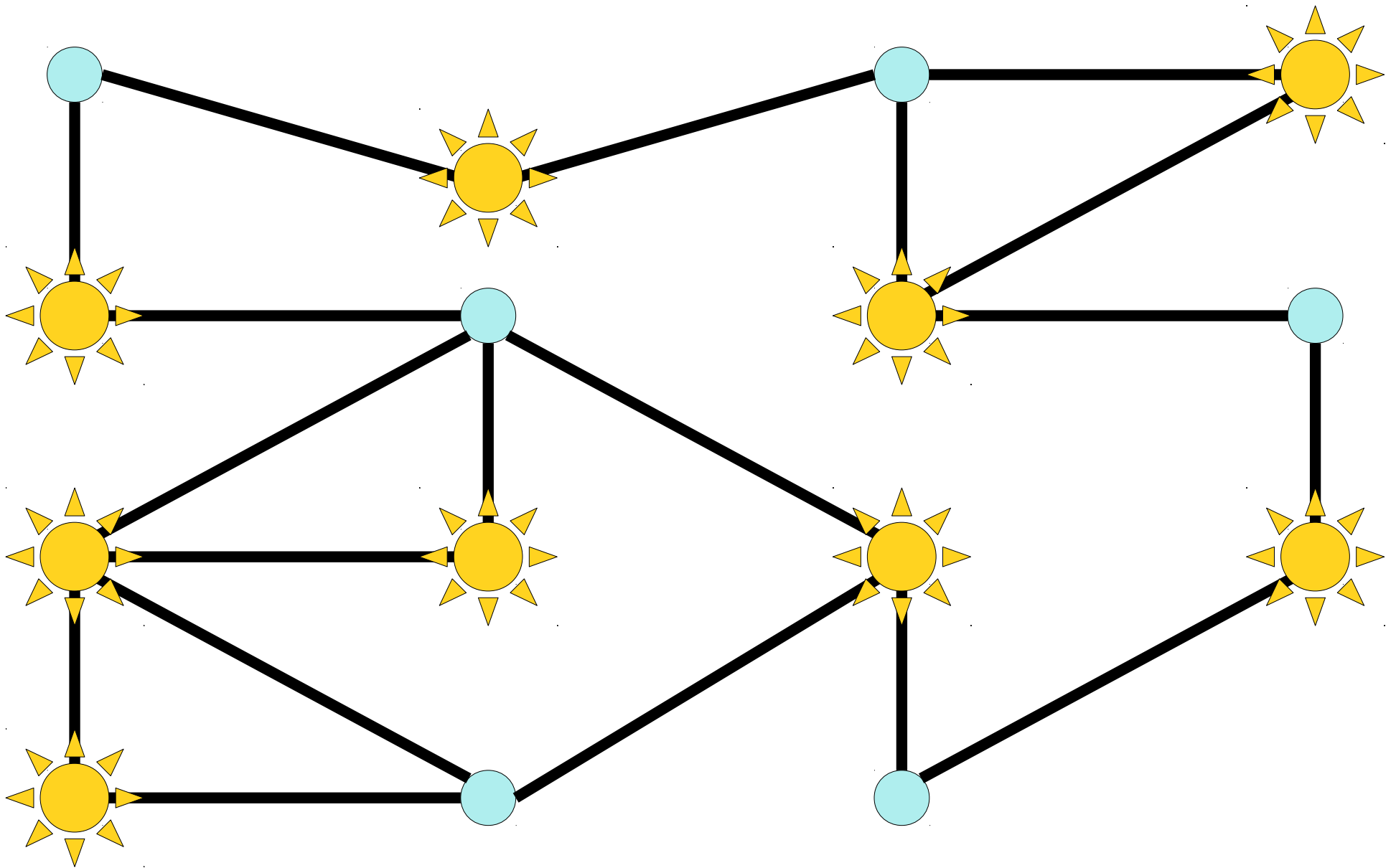

---

Choose at least one endpoint of each edge.



# Vertex Covers

- Let  $G = (V, E)$  be an undirected graph. A **vertex cover** of  $G$  is a set  $C \subseteq V$  such that the following statement is true:

$$\forall u \in V. \forall v \in V. (\{u, v\} \in E \rightarrow (u \in C \vee v \in C))$$

*(“Every edge has at least one endpoint in  $C$ .”)*

- Intuitively speaking, a vertex cover is a set formed by picking at least one endpoint of each edge in the graph.
- Vertex covers have applications to placing streetlights/benches/security guards, as well as in gene sequencing, machine learning, and combinatorics.

A Separate Motivating Problem



Set up nests for the California condor. Condors are territorial and won't nest if they can see other condors.



Set up nests for the California condor. Condors are territorial and won't nest if they can see other condors.

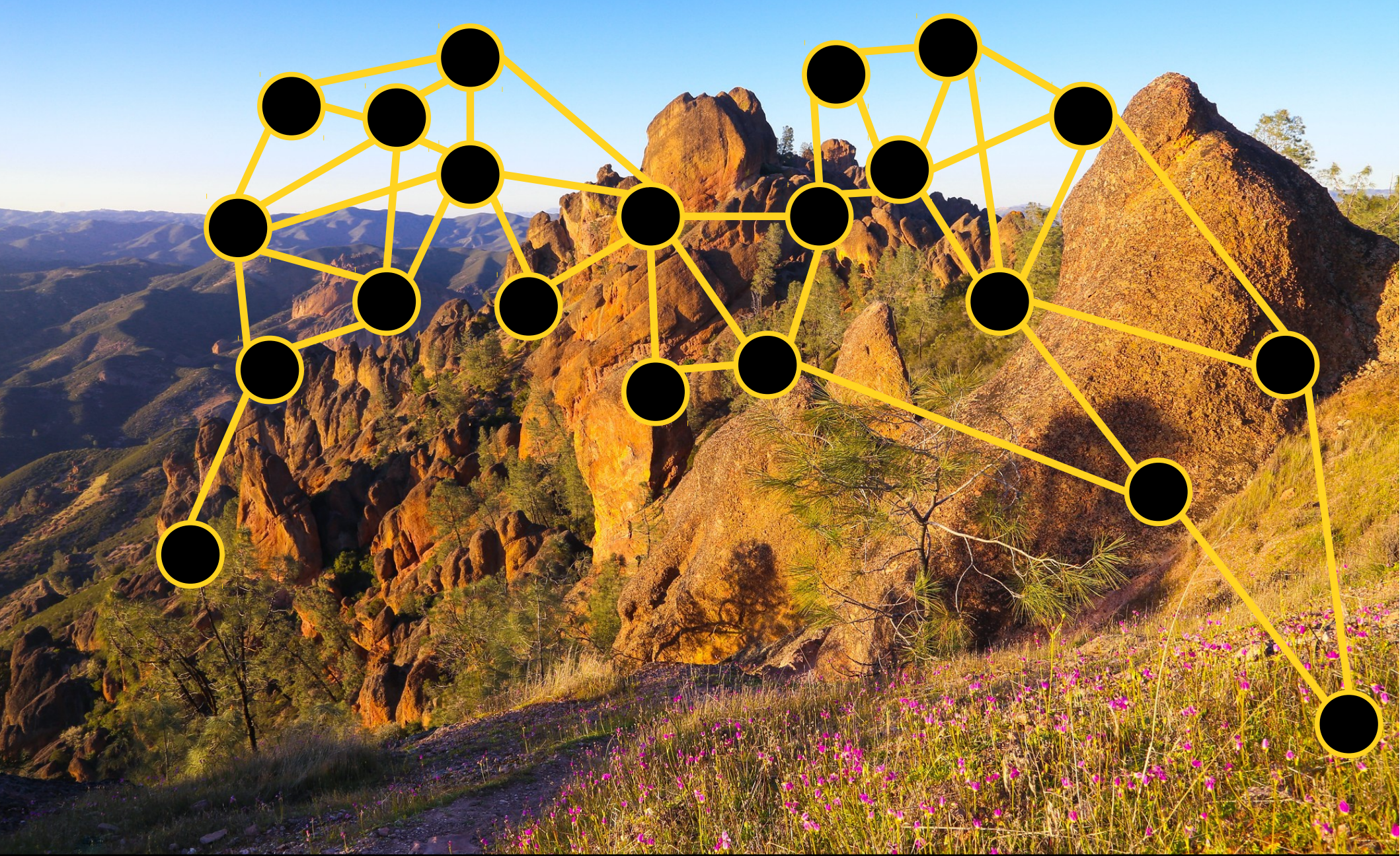

Set up nests for the California condor. Condors are territorial and won't nest if they can see other condors.

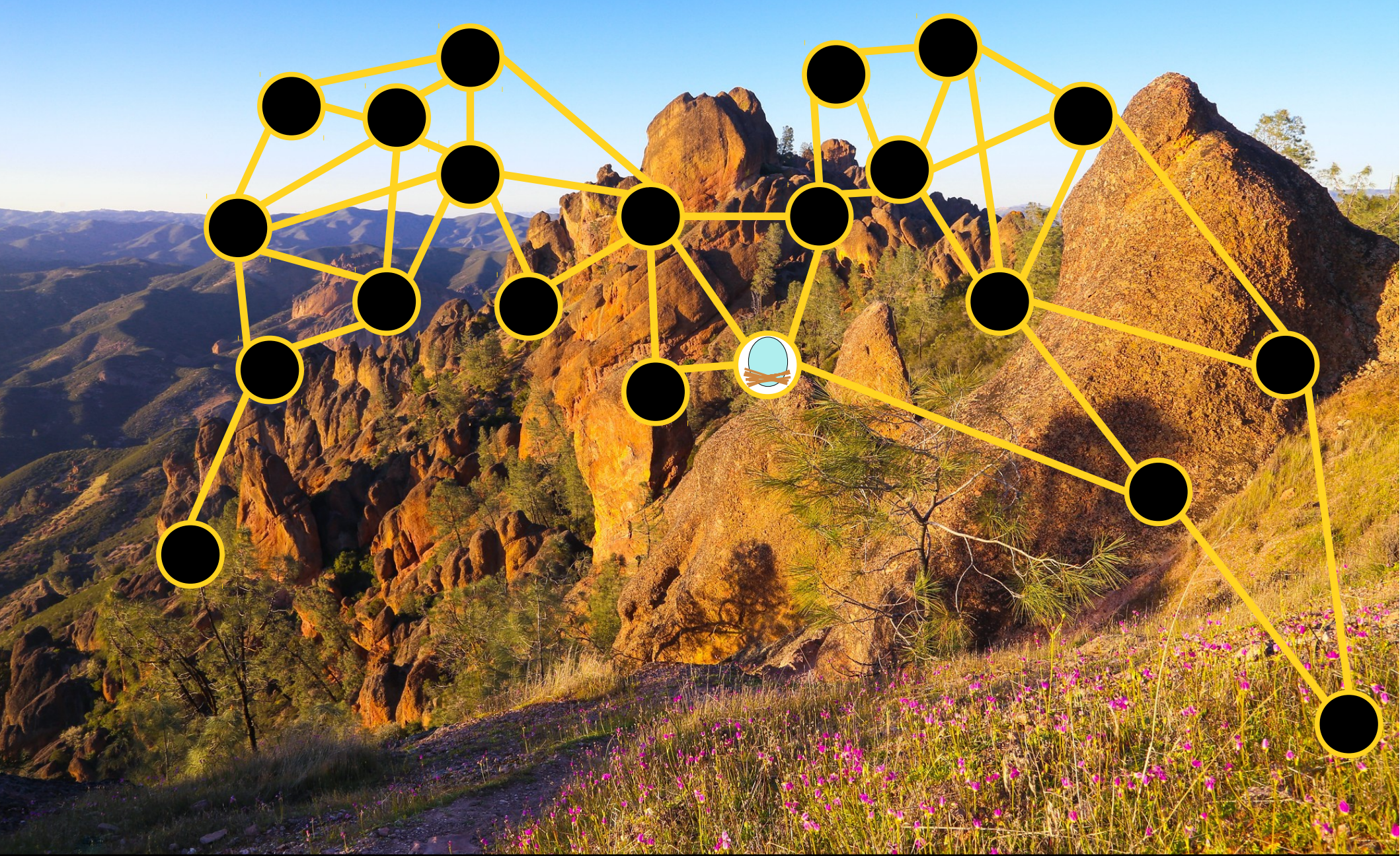

Set up nests for the California condor. Condors are territorial and won't nest if they can see other condors.

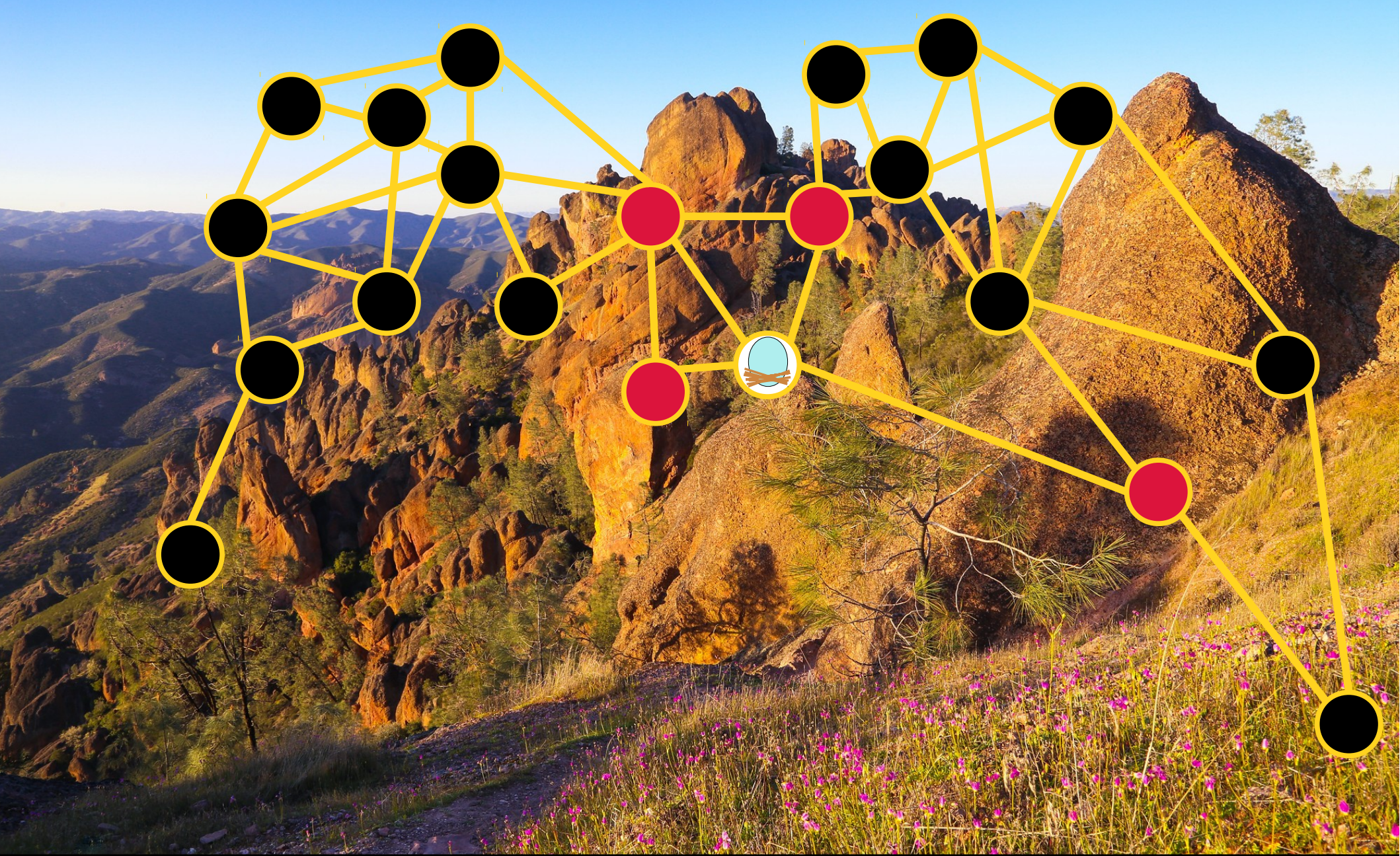

Set up nests for the California condor. Condors are territorial and won't nest if they can see other condors.

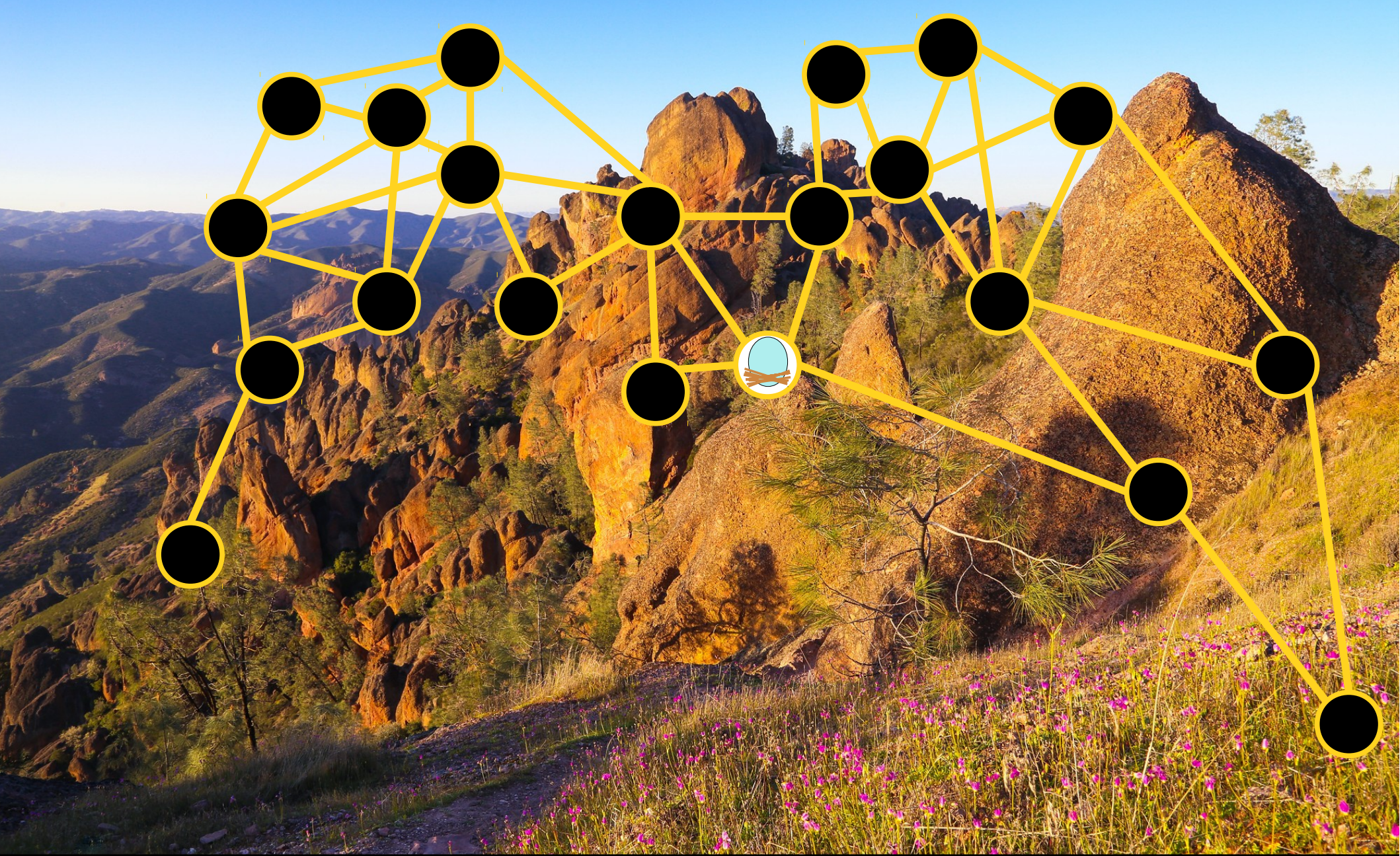

Set up nests for the California condor. Condors are territorial and won't nest if they can see other condors.

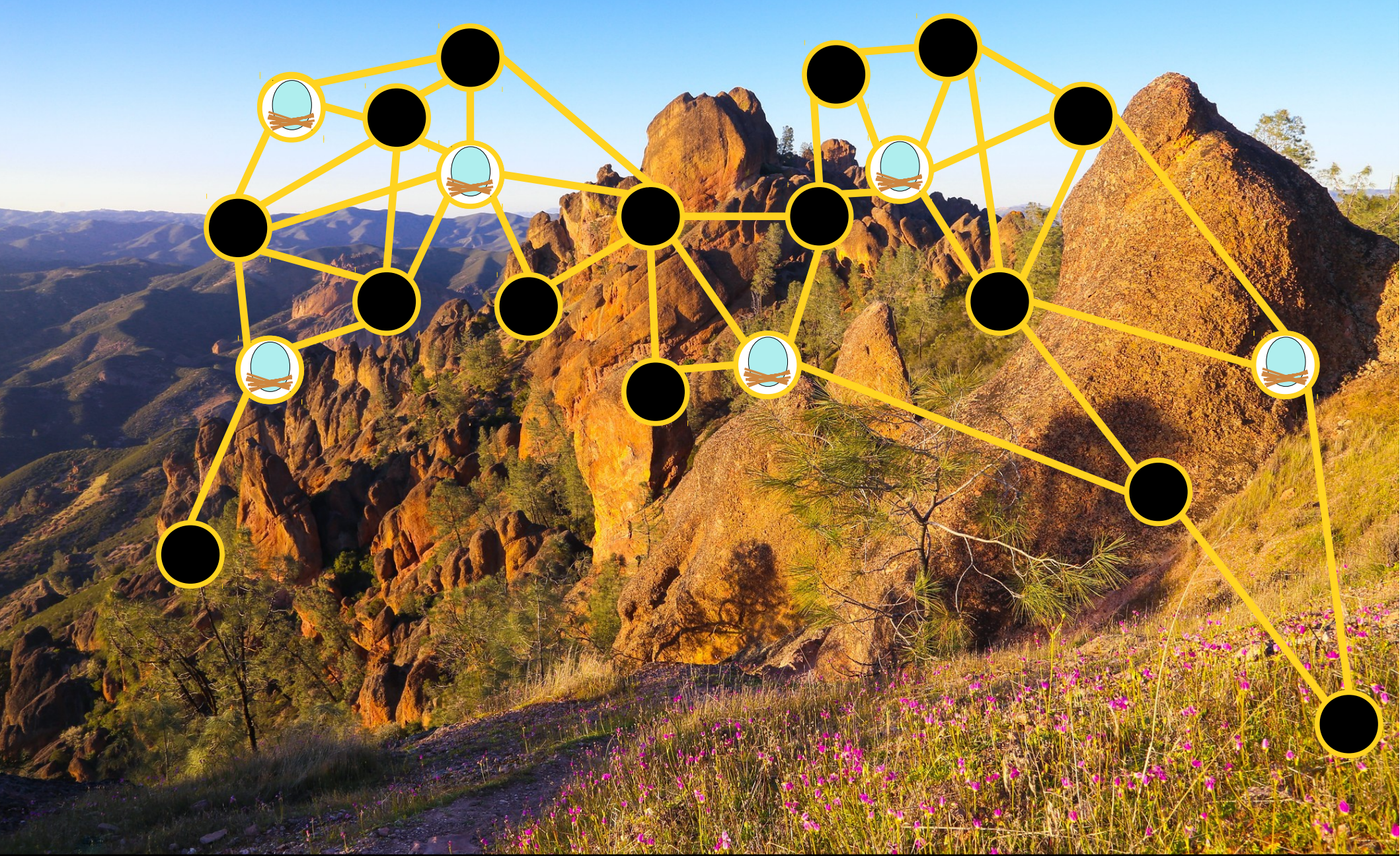

Set up nests for the California condor. Condors are territorial and won't nest if they can see other condors.

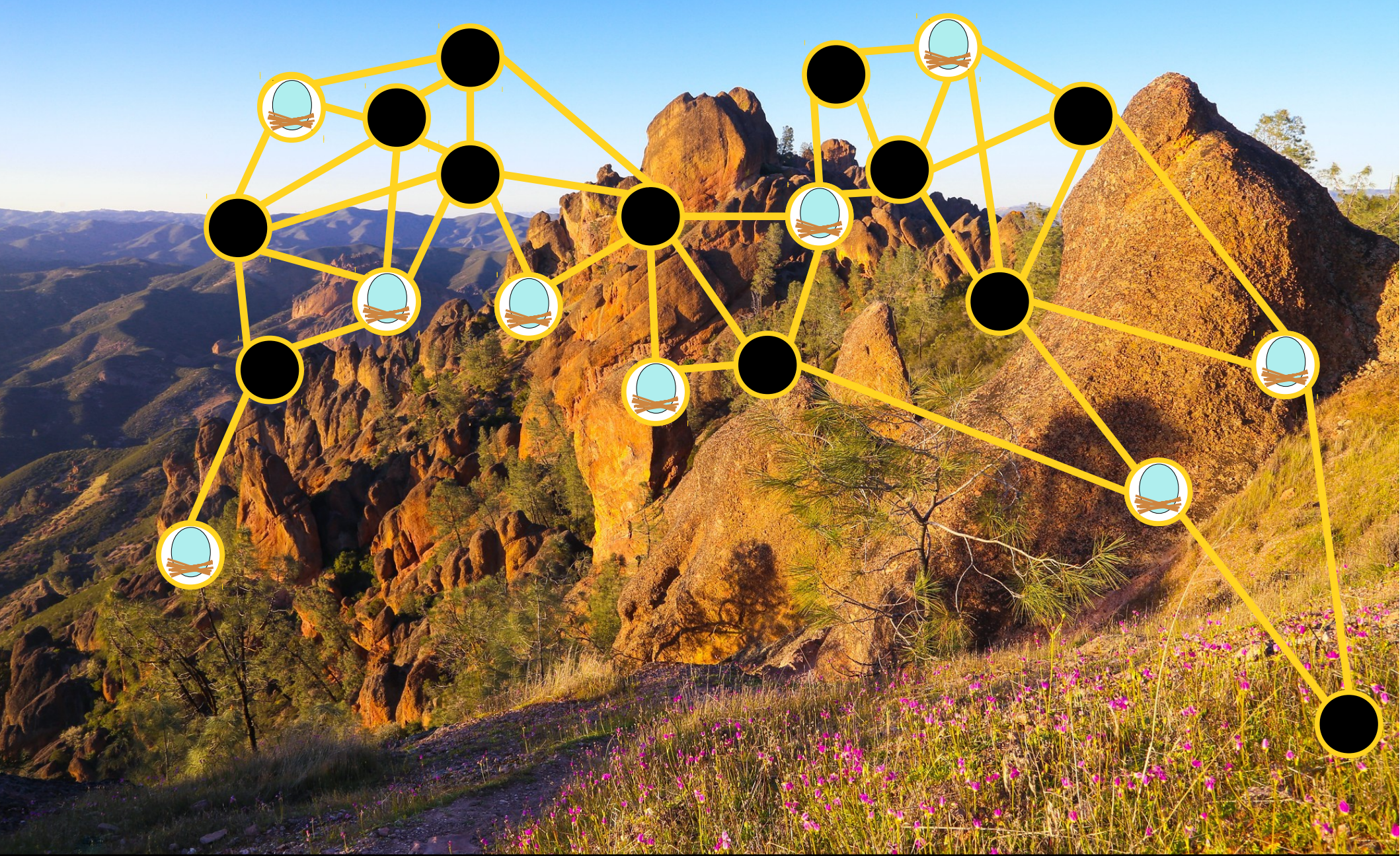

Set up nests for the California condor. Condors are territorial and won't nest if they can see other condors.

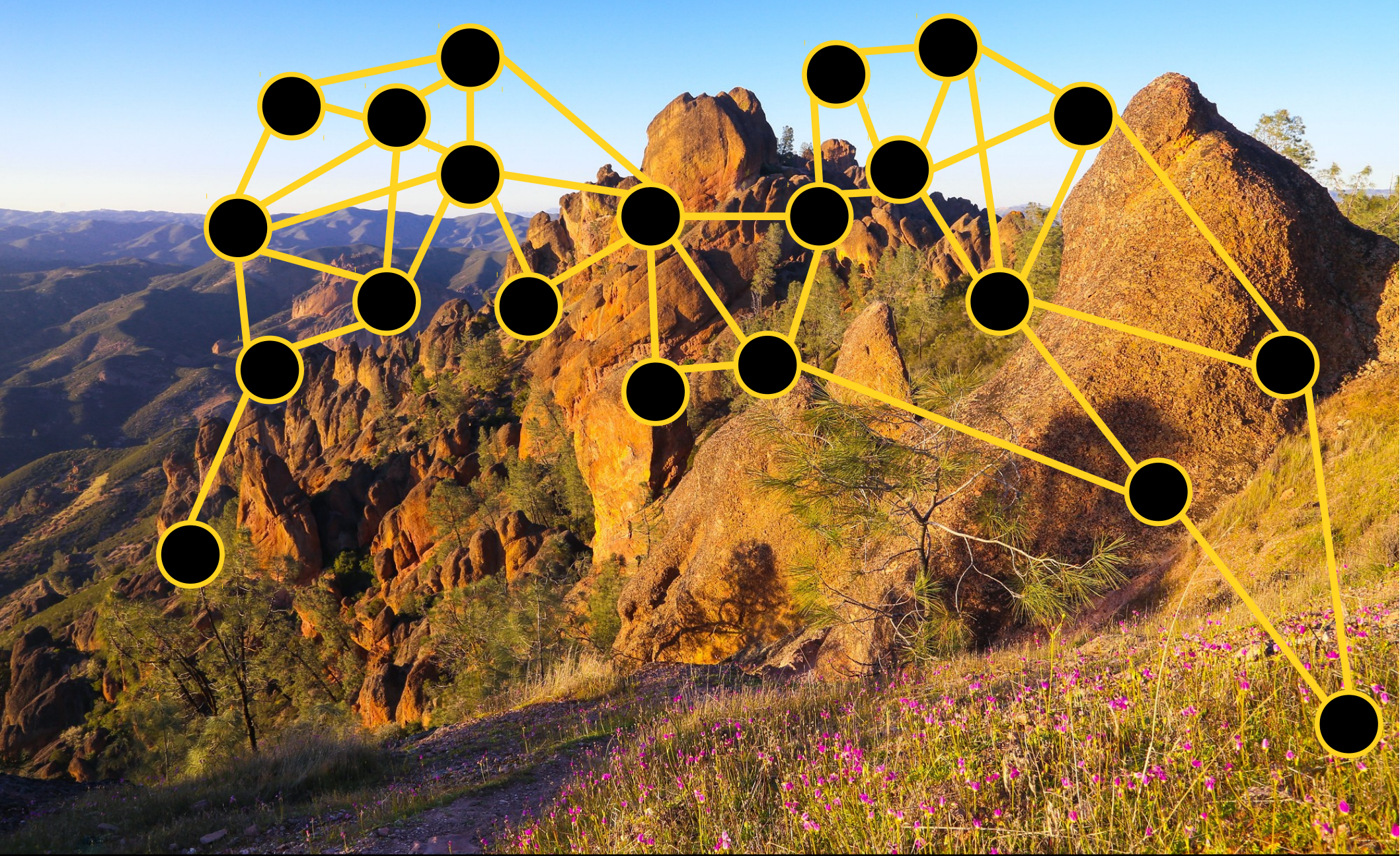

Set up nests for the California condor. Condors are territorial and won't nest if they can see other condors.

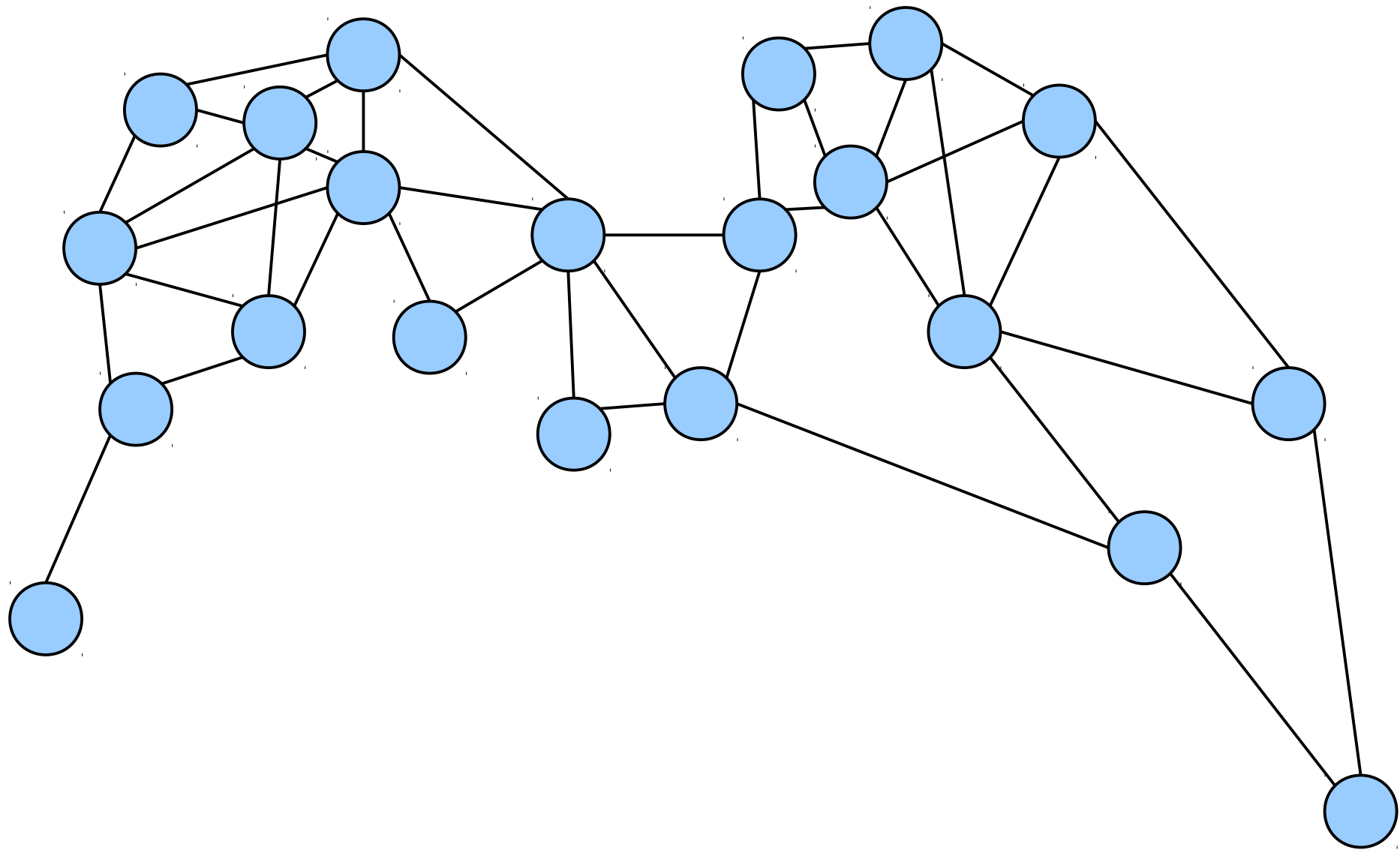

---

Set up nests for the California condor. Condors are territorial and won't nest if they can see other condors.

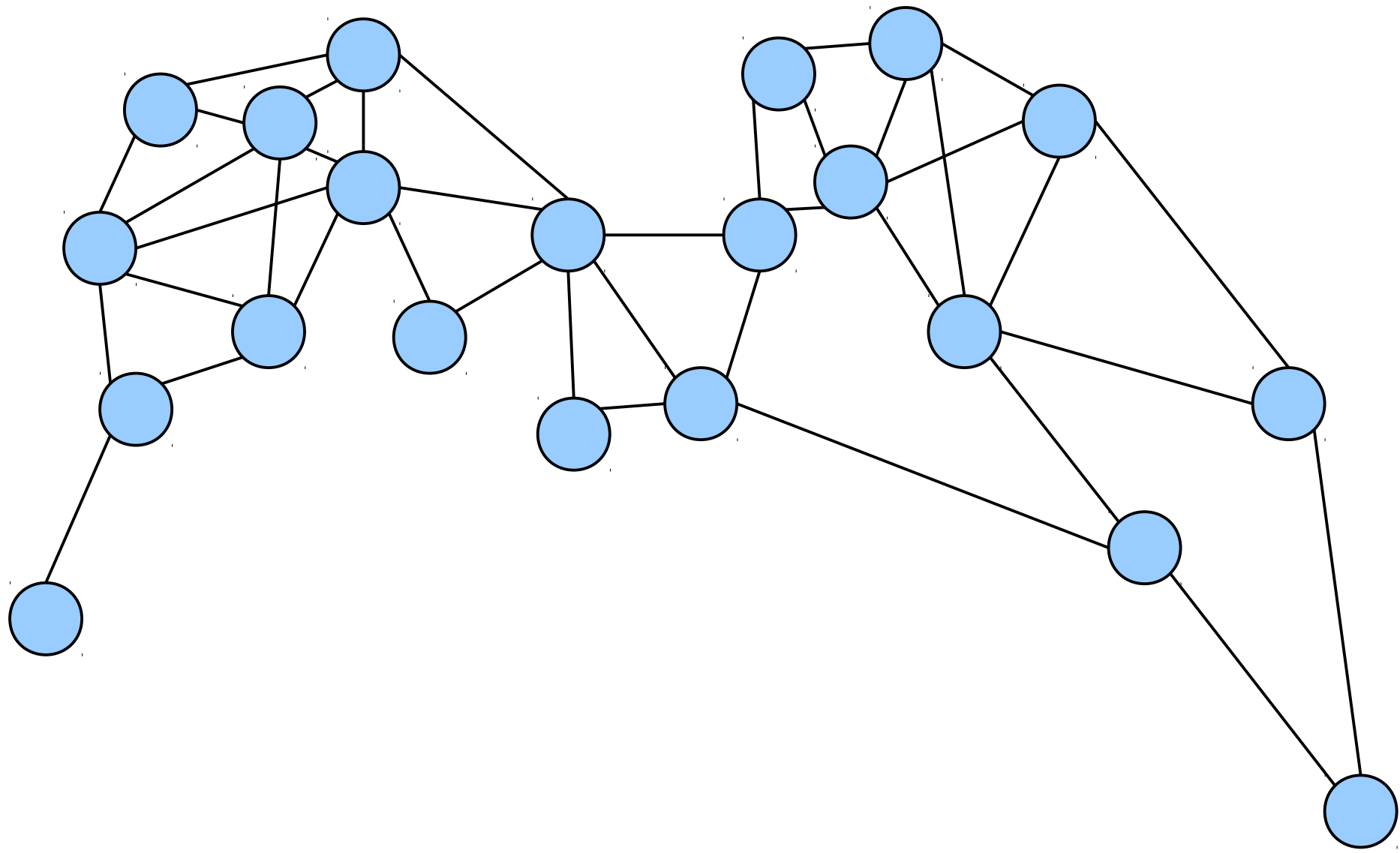

---

Choose a set of nodes, no two of which are adjacent.

# Independent Sets

- If  $G = (V, E)$  is an (undirected) graph, then an ***independent set*** in  $G$  is a set  $I \subseteq V$  such that

$$\forall x \in I. \forall y \in I. \{x, y\} \notin E.$$

*(“No two nodes in  $I$  are adjacent.”)*

- Independent sets have applications to resource optimization, conflict minimization, error-correcting codes, cryptography, and more.

# A Connection

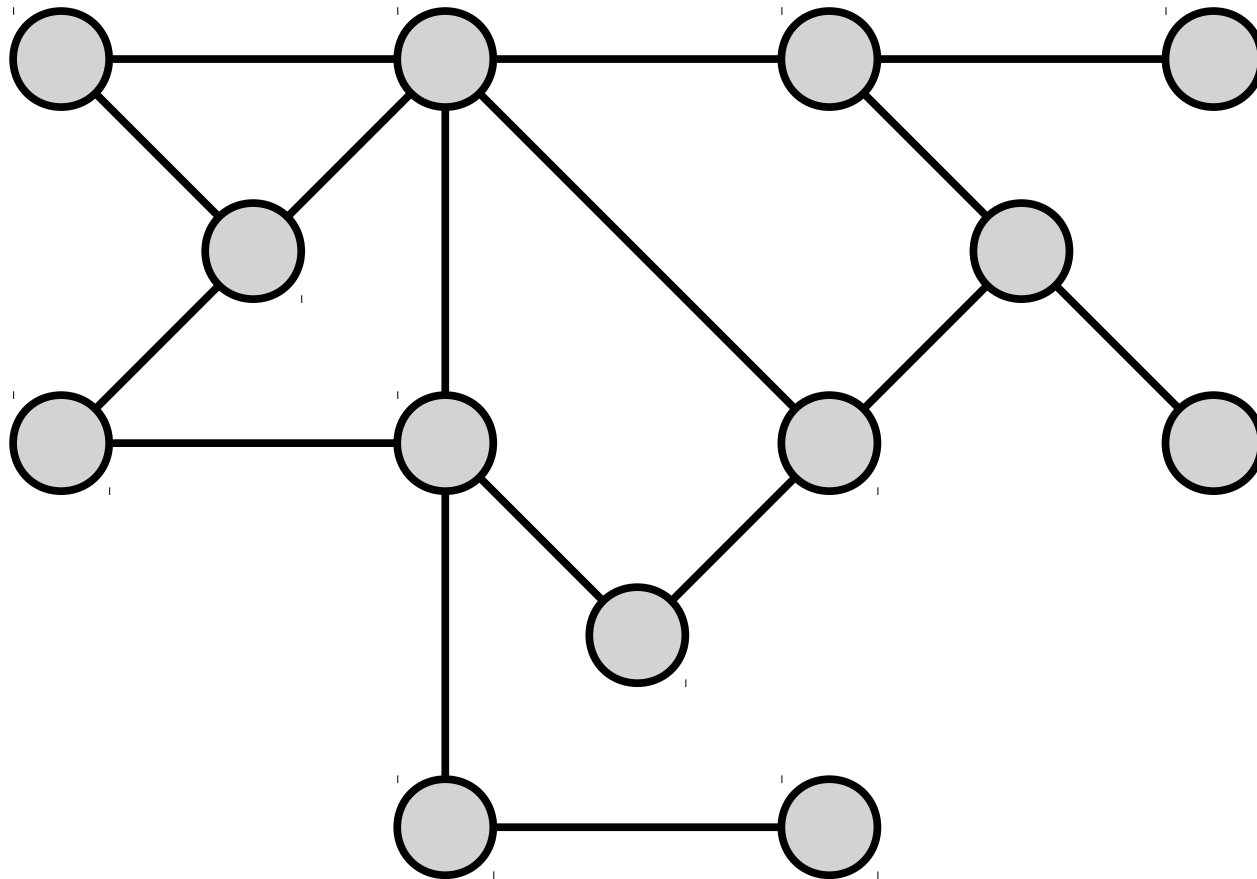

---

Independent sets and vertex covers are related.

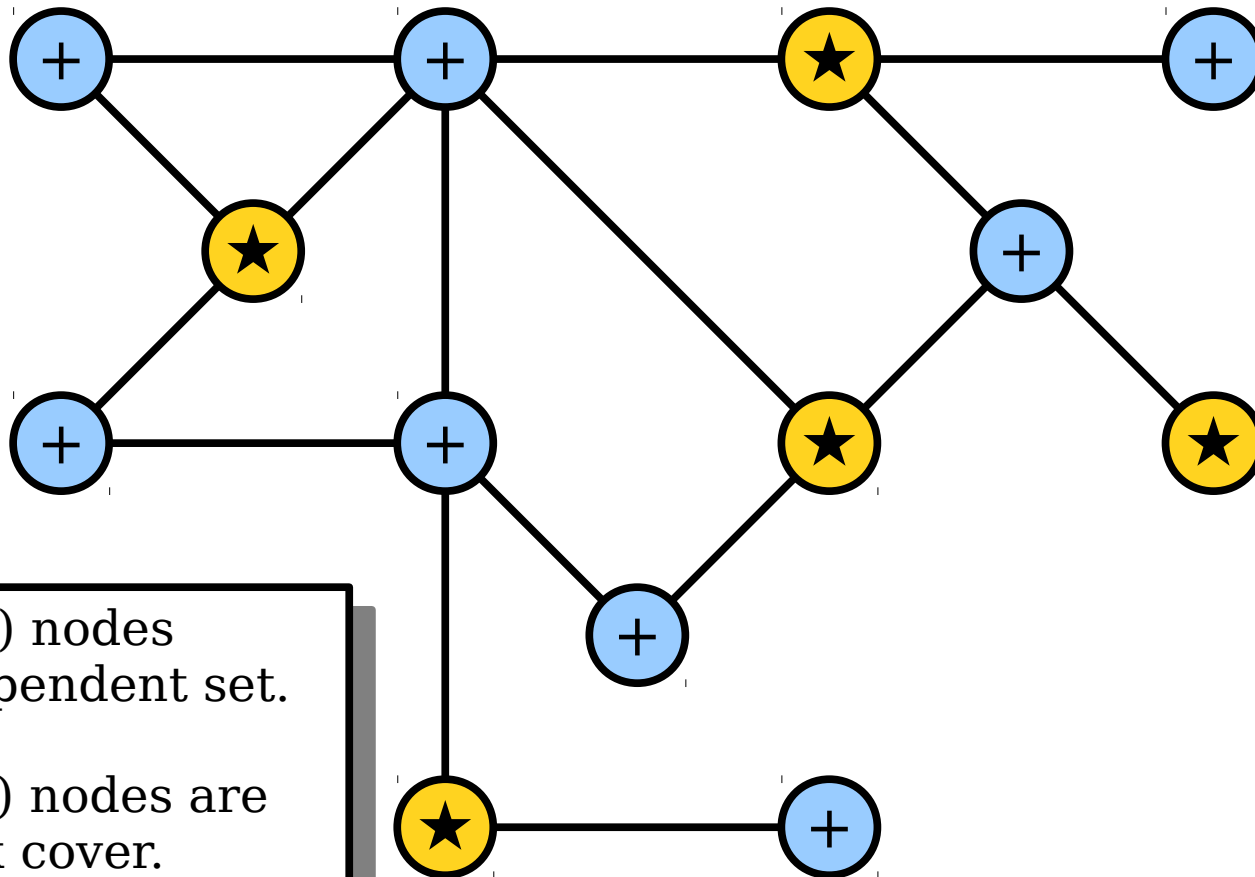

■ The star (★) nodes are an independent set.

■ The plus (+) nodes are a vertex cover.

Independent sets and vertex covers are related.

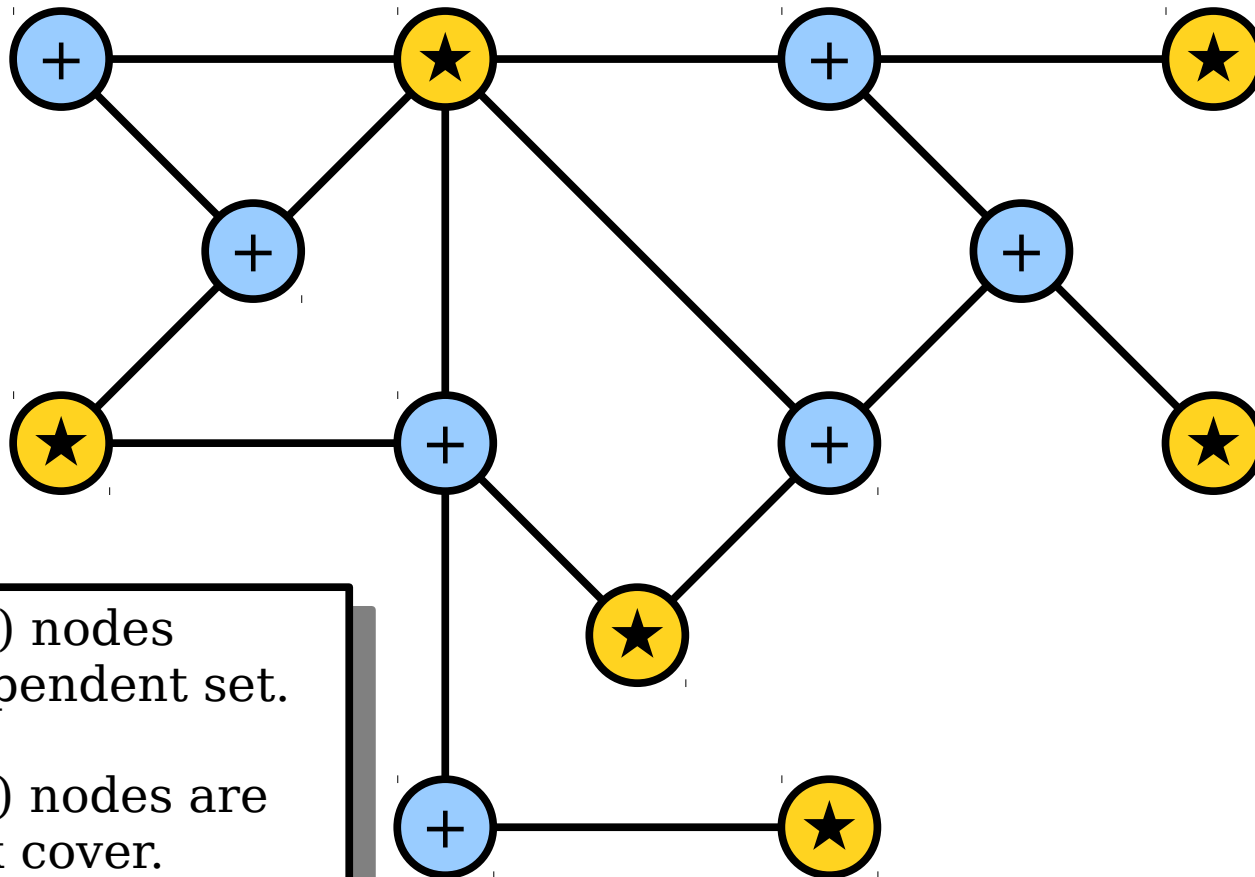

■ The star (★) nodes are an independent set.  
■ The plus (+) nodes are a vertex cover.

Independent sets and vertex covers are related.

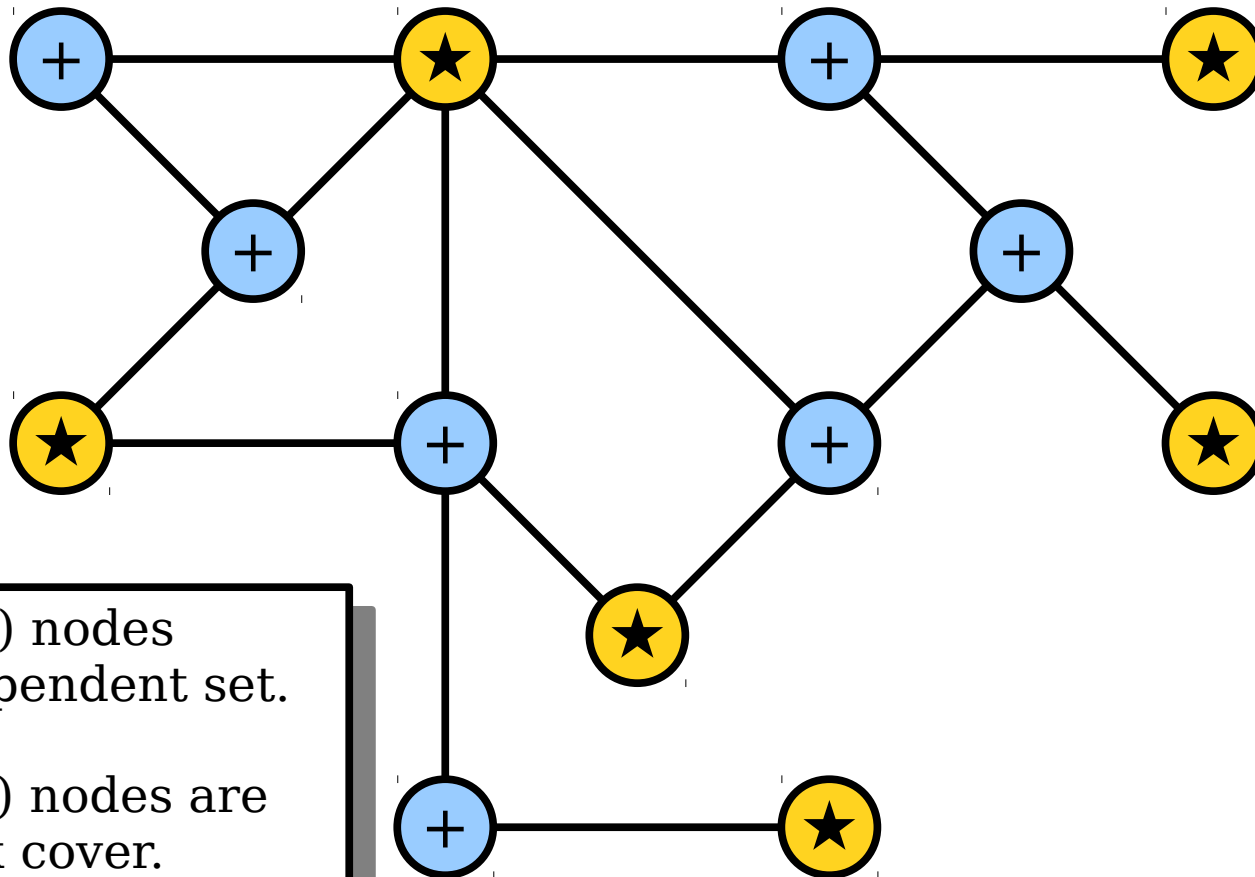

■ The star (★) nodes are an independent set.

■ The plus (+) nodes are a vertex cover.

**Theorem:** Let  $G = (V, E)$  be a graph and let  $C \subseteq V$  be a set. Then  $C$  is a vertex cover of  $G$  if and only if  $V - C$  is an independent set in  $G$ .

**Lemma 1:** Let  $G = (V, E)$  be a graph and let  $C \subseteq V$  be a set. If  $C$  is a vertex cover of  $G$ , then  $V - C$  is an independent set in  $G$ .

### *What We're Assuming*

$G$  is a graph.

$C$  is a vertex cover of  $G$ .

$\forall u \in V. \forall v \in V. (\{u, v\} \in E \rightarrow$   
 $u \in C \vee v \in C$   
)

### *What We Need To Show*

$V - C$  is an independent set in  $G$ .

$\forall x \in V - C.$

$\forall y \in V - C.$

$\{x, y\} \notin E.$

Based on the assume/prove columns, which of  $u$ ,  $v$ ,  $x$ , and  $y$  should we introduce?

Go to  
[PollEv.com/cs103spr26](https://PollEv.com/cs103spr26)

**Lemma 1:** Let  $G = (V, E)$  be a graph and let  $C \subseteq V$  be a set. If  $C$  is a vertex cover of  $G$ , then  $V - C$  is an independent set in  $G$ .

### *What We're Assuming*

$G$  is a graph.

$C$  is a vertex cover of  $G$ .

$$\forall u \in V. \forall v \in V. (\{u, v\} \in E \rightarrow$$
$$u \in C \vee v \in C$$
$$)$$

We're assuming a universally-quantified statement. That means we **don't do anything right now** and instead wait for an edge to present itself.

### *What We Need To Show*

$V - C$  is an independent set in  $G$ .

$$\forall x \in V - C.$$
$$\forall y \in V - C.$$
$$\{x, y\} \notin E.$$

We need to prove a universally-quantified statement. We'll ask the reader to pick arbitrary choices of  $x$  and  $y$  for us to work with.

**Lemma 1:** Let  $G = (V, E)$  be a graph and let  $C \subseteq V$  be a set. If  $C$  is a vertex cover of  $G$ , then  $V - C$  is an independent set in  $G$ .

### *What We're Assuming*

$G$  is a graph.

$C$  is a vertex cover of  $G$ .

$$\forall u \in V. \forall v \in V. (\{u, v\} \in E \rightarrow u \in C \vee v \in C)$$

### *What We Need To Show*

$V - C$  is an independent set in  $G$ .

$$\forall x \in V - C.$$
$$\forall y \in V - C.$$
$$\{x, y\} \notin E.$$

We need to prove a universally-quantified statement. We'll ask the reader to pick arbitrary choices of  $x$  and  $y$  for us to work with.

**Lemma 1:** Let  $G = (V, E)$  be a graph and let  $C \subseteq V$  be a set. If  $C$  is a vertex cover of  $G$ , then  $V - C$  is an independent set in  $G$ .

### *What We're Assuming*

$G$  is a graph.

$C$  is a vertex cover of  $G$ .

$$\forall u \in V. \forall v \in V. (\{u, v\} \in E \rightarrow \\ u \in C \vee v \in C \\ )$$

$$x \in V - C.$$

$$y \in V - C.$$

### *What We Need To Show*

$V - C$  is an independent set in  $G$ .

$$\forall x \in V - C.$$

$$\forall y \in V - C.$$

$$\{x, y\} \notin E.$$

**Lemma 1:** Let  $G = (V, E)$  be a graph and let  $C \subseteq V$  be a set. If  $C$  is a vertex cover of  $G$ , then  $V - C$  is an independent set in  $G$ .

### *What We're Assuming*

$G$  is a graph.

$C$  is a vertex cover of  $G$ .

$$\forall u \in V. \forall v \in V. (\{u, v\} \in E \rightarrow u \in C \vee v \in C)$$

$x \in V$  and  $x \notin C$ .

$y \in V$  and  $y \notin C$ .

### *What We Need To Show*

$V - C$  is an independent set in  $G$ .

$$\forall x \in V - C.$$

$$\forall y \in V - C.$$

$$\{x, y\} \notin E.$$

**Lemma 1:** Let  $G = (V, E)$  be a graph and let  $C \subseteq V$  be a set. If  $C$  is a vertex cover of  $G$ , then  $V - C$  is an independent set in  $G$ .

### *What We're Assuming*

$G$  is a graph.

$C$  is a vertex cover of  $G$ .

$$\forall u \in V. \forall v \in V. (\{u, v\} \in E \rightarrow u \in C \vee v \in C)$$

$x \in V$  and  $x \notin C$ .

$y \in V$  and  $y \notin C$ .

### *What We Need To Show*

$V - C$  is an independent set in  $G$ .

$$\forall x \in V - C.$$

$$\forall y \in V - C.$$

$$\{x, y\} \notin E.$$



If this edge exists, at least one of  $x$  and  $y$  is in  $C$ .

**Lemma 1:** Let  $G = (V, E)$  be a graph and let  $C \subseteq V$  be a set. If  $C$  is a vertex cover of  $G$ , then  $V - C$  is an independent set in  $G$ .

### *What We're Assuming*

$G$  is a graph.

$C$  is a vertex cover of  $G$ .

$$\forall u \in V. \forall v \in V. (\{u, v\} \in E \rightarrow u \in C \vee v \in C)$$

$x \in V$  and  $x \notin C$ .

$y \in V$  and  $y \notin C$ .

### *What We Need To Show*

$V - C$  is an independent set in  $G$ .

$$\forall x \in V - C.$$

$$\forall y \in V - C.$$

$$\{x, y\} \notin E.$$



If this edge exists, at least one of  $x$  and  $y$  is in  $C$ .

***Lemma 1:*** Let  $G = (V, E)$  be a graph and let  $C \subseteq V$  be a set. If  $C$  is a vertex cover of  $G$ , then  $V - C$  is an independent set of  $G$ .

**Lemma 1:** Let  $G = (V, E)$  be a graph and let  $C \subseteq V$  be a set. If  $C$  is a vertex cover of  $G$ , then  $V - C$  is an independent set of  $G$ .

**Proof:**

**Lemma 1:** Let  $G = (V, E)$  be a graph and let  $C \subseteq V$  be a set. If  $C$  is a vertex cover of  $G$ , then  $V - C$  is an independent set of  $G$ .

**Proof:** Assume  $C$  is a vertex cover of  $G$ .

There's no need to introduce  $G$  or  $C$  here. That's done in the statement of the lemma itself.

**Lemma 1:** Let  $G = (V, E)$  be a graph and let  $C \subseteq V$  be a set. If  $C$  is a vertex cover of  $G$ , then  $V - C$  is an independent set of  $G$ .

**Proof:** Assume  $C$  is a vertex cover of  $G$ . We need to show that  $V - C$  is an independent set of  $G$ .

**Lemma 1:** Let  $G = (V, E)$  be a graph and let  $C \subseteq V$  be a set. If  $C$  is a vertex cover of  $G$ , then  $V - C$  is an independent set of  $G$ .

**Proof:** Assume  $C$  is a vertex cover of  $G$ . We need to show that  $V - C$  is an independent set of  $G$ . To do so, pick any nodes  $x, y \in V - C$ ; we will show that  $\{x, y\} \notin E$ .

**Lemma 1:** Let  $G = (V, E)$  be a graph and let  $C \subseteq V$  be a set. If  $C$  is a vertex cover of  $G$ , then  $V - C$  is an independent set of  $G$ .

**Proof:** Assume  $C$  is a vertex cover of  $G$ . We need to show that  $V - C$  is an independent set of  $G$ . To do so, pick any nodes  $x, y \in V - C$ ; we will show that  $\{x, y\} \notin E$ .

Suppose for the sake of contradiction that  $\{x, y\} \in E$ .

**Lemma 1:** Let  $G = (V, E)$  be a graph and let  $C \subseteq V$  be a set. If  $C$  is a vertex cover of  $G$ , then  $V - C$  is an independent set of  $G$ .

**Proof:** Assume  $C$  is a vertex cover of  $G$ . We need to show that  $V - C$  is an independent set of  $G$ . To do so, pick any nodes  $x, y \in V - C$ ; we will show that  $\{x, y\} \notin E$ .

Suppose for the sake of contradiction that  $\{x, y\} \in E$ . Because  $x, y \in V - C$ , we know that  $x \notin C$  and  $y \notin C$ .

**Lemma 1:** Let  $G = (V, E)$  be a graph and let  $C \subseteq V$  be a set. If  $C$  is a vertex cover of  $G$ , then  $V - C$  is an independent set of  $G$ .

**Proof:** Assume  $C$  is a vertex cover of  $G$ . We need to show that  $V - C$  is an independent set of  $G$ . To do so, pick any nodes  $x, y \in V - C$ ; we will show that  $\{x, y\} \notin E$ .

Suppose for the sake of contradiction that  $\{x, y\} \in E$ . Because  $x, y \in V - C$ , we know that  $x \notin C$  and  $y \notin C$ . However, since  $C$  is a vertex cover of  $G$  and  $\{x, y\} \in E$ , we also see that  $x \in C$  or  $y \in C$ , contradicting our previous statement.

**Lemma 1:** Let  $G = (V, E)$  be a graph and let  $C \subseteq V$  be a set. If  $C$  is a vertex cover of  $G$ , then  $V - C$  is an independent set of  $G$ .

**Proof:** Assume  $C$  is a vertex cover of  $G$ . We need to show that  $V - C$  is an independent set of  $G$ . To do so, pick any nodes  $x, y \in V - C$ ; we will show that  $\{x, y\} \notin E$ .

Suppose for the sake of contradiction that  $\{x, y\} \in E$ . Because  $x, y \in V - C$ , we know that  $x \notin C$  and  $y \notin C$ . However, since  $C$  is a vertex cover of  $G$  and  $\{x, y\} \in E$ , we also see that  $x \in C$  or  $y \in C$ , contradicting our previous statement.

We've reached a contradiction, so our assumption was wrong.

**Lemma 1:** Let  $G = (V, E)$  be a graph and let  $C \subseteq V$  be a set. If  $C$  is a vertex cover of  $G$ , then  $V - C$  is an independent set of  $G$ .

**Proof:** Assume  $C$  is a vertex cover of  $G$ . We need to show that  $V - C$  is an independent set of  $G$ . To do so, pick any nodes  $x, y \in V - C$ ; we will show that  $\{x, y\} \notin E$ .

Suppose for the sake of contradiction that  $\{x, y\} \in E$ . Because  $x, y \in V - C$ , we know that  $x \notin C$  and  $y \notin C$ . However, since  $C$  is a vertex cover of  $G$  and  $\{x, y\} \in E$ , we also see that  $x \in C$  or  $y \in C$ , contradicting our previous statement.

We've reached a contradiction, so our assumption was wrong. Therefore, we have  $\{x, y\} \notin E$ , as required.

**Lemma 1:** Let  $G = (V, E)$  be a graph and let  $C \subseteq V$  be a set. If  $C$  is a vertex cover of  $G$ , then  $V - C$  is an independent set of  $G$ .

**Proof:** Assume  $C$  is a vertex cover of  $G$ . We need to show that  $V - C$  is an independent set of  $G$ . To do so, pick any nodes  $x, y \in V - C$ ; we will show that  $\{x, y\} \notin E$ .

Suppose for the sake of contradiction that  $\{x, y\} \in E$ . Because  $x, y \in V - C$ , we know that  $x \notin C$  and  $y \notin C$ . However, since  $C$  is a vertex cover of  $G$  and  $\{x, y\} \in E$ , we also see that  $x \in C$  or  $y \in C$ , contradicting our previous statement.

We've reached a contradiction, so our assumption was wrong. Therefore, we have  $\{x, y\} \notin E$ , as required. ■

**Lemma 2:** Let  $G = (V, E)$  be a graph and let  $C \subseteq V$  be a set. If  $C$  is not a vertex cover of  $G$ , then  $V - C$  is not an independent set in  $G$ .

# Taking Negations

- What is the negation of this statement, which says “ $C$  is a vertex cover?”

$$\forall u \in V. \forall v \in V. (\{u, v\} \in E \rightarrow \\ u \in C \vee v \in C \\ )$$

# Taking Negations

- What is the negation of this statement, which says “ $C$  is a vertex cover?”

$$\neg \forall u \in V. \forall v \in V. (\{u, v\} \in E \rightarrow u \in C \vee v \in C)$$

# Taking Negations

- What is the negation of this statement, which says “ $C$  is a vertex cover?”

$$\exists u \in V. \neg \forall v \in V. (\{u, v\} \in E \rightarrow u \in C \vee v \in C)$$

# Taking Negations

- What is the negation of this statement, which says “ $C$  is a vertex cover?”

$$\exists u \in V. \exists v \in V. \neg(\{u, v\} \in E \rightarrow u \in C \vee v \in C)$$

# Taking Negations

- What is the negation of this statement, which says “ $C$  is a vertex cover?”

$$\exists u \in V. \exists v \in V. (\{u, v\} \in E \wedge \neg(u \in C \vee v \in C))$$

# Taking Negations

- What is the negation of this statement, which says “ $C$  is a vertex cover?”

$$\begin{aligned} & \exists u \in V. \exists v \in V. (\{u, v\} \in E \wedge \\ & \quad u \notin C \quad \wedge \quad v \notin C \\ & ) \end{aligned}$$

# Taking Negations

- What is the negation of this statement, which says “ $C$  is a vertex cover?”

$$\exists u \in V. \exists v \in V. (\{u, v\} \in E \wedge \\ u \notin C \wedge v \notin C \\ )$$

- This says “there is an edge where both endpoints aren’t in  $C$ .”

# Taking Negations

- What is the negation of this statement, which says “ $V - C$  is an independent set?”

$$\forall u \in V - C. \forall v \in V - C. \{u, v\} \notin E$$

# Taking Negations

- What is the negation of this statement, which says “ $V - C$  is an independent set?”

$$\neg \forall u \in V - C. \forall v \in V - C. \{u, v\} \notin E$$

# Taking Negations

- What is the negation of this statement, which says “ $V - C$  is an independent set?”

$$\exists u \in V - C. \neg \forall v \in V - C. \{u, v\} \notin E$$

# Taking Negations

- What is the negation of this statement, which says “ $V - C$  is an independent set?”

$$\exists u \in V - C. \exists v \in V - C. \neg(\{u, v\} \notin E)$$

# Taking Negations

- What is the negation of this statement, which says “ $V - C$  is an independent set?”

$$\exists u \in V - C. \exists v \in V - C. \{u, v\} \in E$$

# Taking Negations

- What is the negation of this statement, which says “ $V - C$  is an independent set?”

$$\exists u \in V - C. \exists v \in V - C. \{u, v\} \in E$$

- This says “there are two adjacent nodes in  $V - C$ .”

**Lemma 2:** Let  $G = (V, E)$  be a graph and let  $C \subseteq V$  be a set. If  $C$  is not a vertex cover of  $G$ , then  $V - C$  is not an independent set in  $G$ .

*What We're Assuming*

$G$  is a graph.

$C$  is not a vertex cover of  $G$ .

$\exists u \in V. \exists v \in V. (\{u, v\} \in E \wedge$   
 $u \notin C \wedge v \notin C$   
)

*What We Need To Show*

$V - C$  is not an ind. set in  $G$ .

$\exists x \in V - C.$

$\exists y \in V - C.$

$\{x, y\} \in E.$

**Lemma 2:** Let  $G = (V, E)$  be a graph and let  $C \subseteq V$  be a set. If  $C$  is not a vertex cover of  $G$ , then  $V - C$  is not an independent set in  $G$ .

### *What We're Assuming*

$G$  is a graph.

$C$  is not a vertex cover of  $G$ .

$$\exists u \in V. \exists v \in V. (\{u, v\} \in E \wedge u \notin C \wedge v \notin C)$$

We're assuming an existentially-quantified statement, so we'll **immediately** introduce variables  $u$  and  $v$ .

### *What We Need To Show*

$V - C$  is not an ind. set in  $G$ .

$$\exists x \in V - C.$$
$$\exists y \in V - C.$$
$$\{x, y\} \in E.$$

We're proving an existentially-quantified statement, so we **don't** introduce variables  $x$  and  $y$ . We're on a scavenger hunt!

**Lemma 2:** Let  $G = (V, E)$  be a graph and let  $C \subseteq V$  be a set. If  $C$  is not a vertex cover of  $G$ , then  $V - C$  is not an independent set in  $G$ .

### *What We're Assuming*

$G$  is a graph.

$C$  is not a vertex cover of  $G$ .

$$u \in V - C.$$

$$v \in V - C.$$

$$\{u, v\} \in E.$$

### *What We Need To Show*

$V - C$  is not an ind. set in  $G$ .

$$\exists x \in V - C.$$

$$\exists y \in V - C.$$

$$\{x, y\} \in E.$$

We're assuming an existentially-quantified statement, so we'll **immediately** introduce variables  $u$  and  $v$ .

**Lemma 2:** Let  $G = (V, E)$  be a graph and let  $C \subseteq V$  be a set. If  $C$  is not a vertex cover of  $G$ , then  $V - C$  is not an independent set in  $G$ .

### *What We're Assuming*

$G$  is a graph.

$C$  is not a vertex cover of  $G$ .

$$u \in V - C.$$

$$v \in V - C.$$

$$\{u, v\} \in E.$$

### *What We Need To Show*

$V - C$  is not an ind. set in  $G$ .

$$\exists x \in V - C.$$

$$\exists y \in V - C.$$

$$\{x, y\} \in E.$$

Any ideas about what we should pick  $x$  and  $y$  to be?

**Lemma 2:** Let  $G = (V, E)$  be a graph and let  $C \subseteq V$  be a set. If  $C$  is not a vertex cover of  $G$ , then  $V - C$  is not an independent set of  $G$ .

**Lemma 2:** Let  $G = (V, E)$  be a graph and let  $C \subseteq V$  be a set. If  $C$  is not a vertex cover of  $G$ , then  $V - C$  is not an independent set of  $G$ .

**Proof:**

**Lemma 2:** Let  $G = (V, E)$  be a graph and let  $C \subseteq V$  be a set. If  $C$  is not a vertex cover of  $G$ , then  $V - C$  is not an independent set of  $G$ .

**Proof:** Assume  $C$  is not a vertex cover of  $G$ .

**Lemma 2:** Let  $G = (V, E)$  be a graph and let  $C \subseteq V$  be a set. If  $C$  is not a vertex cover of  $G$ , then  $V - C$  is not an independent set of  $G$ .

**Proof:** Assume  $C$  is not a vertex cover of  $G$ . We need to show that  $V - C$  is not an independent set of  $G$ .

**Lemma 2:** Let  $G = (V, E)$  be a graph and let  $C \subseteq V$  be a set. If  $C$  is not a vertex cover of  $G$ , then  $V - C$  is not an independent set of  $G$ .

**Proof:** Assume  $C$  is not a vertex cover of  $G$ . We need to show that  $V - C$  is not an independent set of  $G$ .

Since  $C$  is not a vertex cover of  $G$ , we know that there exists nodes  $x, y \in V$  where  $\{x, y\} \in E$ , where  $x \notin C$ , and where  $y \notin C$ .

**Lemma 2:** Let  $G = (V, E)$  be a graph and let  $C \subseteq V$  be a set. If  $C$  is not a vertex cover of  $G$ , then  $V - C$  is not an independent set of  $G$ .

**Proof:** Assume  $C$  is not a vertex cover of  $G$ . We need to show that  $V - C$  is not an independent set of  $G$ .

Since  $C$  is not a vertex cover of  $G$ , we know that there exists nodes  $x, y \in V$  where  $\{x, y\} \in E$ , where  $x \notin C$ , and where  $y \notin C$ . Because  $x \in V$  and  $x \notin C$ , we know that  $x \in V - C$ .

**Lemma 2:** Let  $G = (V, E)$  be a graph and let  $C \subseteq V$  be a set. If  $C$  is not a vertex cover of  $G$ , then  $V - C$  is not an independent set of  $G$ .

**Proof:** Assume  $C$  is not a vertex cover of  $G$ . We need to show that  $V - C$  is not an independent set of  $G$ .

Since  $C$  is not a vertex cover of  $G$ , we know that there exists nodes  $x, y \in V$  where  $\{x, y\} \in E$ , where  $x \notin C$ , and where  $y \notin C$ . Because  $x \in V$  and  $x \notin C$ , we know that  $x \in V - C$ . Similarly, we see that  $y \in V - C$ .

**Lemma 2:** Let  $G = (V, E)$  be a graph and let  $C \subseteq V$  be a set. If  $C$  is not a vertex cover of  $G$ , then  $V - C$  is not an independent set of  $G$ .

**Proof:** Assume  $C$  is not a vertex cover of  $G$ . We need to show that  $V - C$  is not an independent set of  $G$ .

Since  $C$  is not a vertex cover of  $G$ , we know that there exists nodes  $x, y \in V$  where  $\{x, y\} \in E$ , where  $x \notin C$ , and where  $y \notin C$ . Because  $x \in V$  and  $x \notin C$ , we know that  $x \in V - C$ . Similarly, we see that  $y \in V - C$ .

This means that  $\{x, y\} \in E$ , that  $x \in V - C$ , and that  $y \in V - C$ , and therefore that  $V - C$  is not an independent set of  $G$ , as required.

**Lemma 2:** Let  $G = (V, E)$  be a graph and let  $C \subseteq V$  be a set. If  $C$  is not a vertex cover of  $G$ , then  $V - C$  is not an independent set of  $G$ .

**Proof:** Assume  $C$  is not a vertex cover of  $G$ . We need to show that  $V - C$  is not an independent set of  $G$ .

Since  $C$  is not a vertex cover of  $G$ , we know that there exists nodes  $x, y \in V$  where  $\{x, y\} \in E$ , where  $x \notin C$ , and where  $y \notin C$ . Because  $x \in V$  and  $x \notin C$ , we know that  $x \in V - C$ . Similarly, we see that  $y \in V - C$ .

This means that  $\{x, y\} \in E$ , that  $x \in V - C$ , and that  $y \in V - C$ , and therefore that  $V - C$  is not an independent set of  $G$ , as required. ■

# Finding an IS or VC

- The previous theorem means that finding a large IS in a graph is equivalent to finding a small VC.
  - If you've found one, you've found the other!
- **Open Problem:** Design an algorithm that, given an  $n$ -node graph, finds either the largest IS or smallest VC “efficiently,” where “efficiently” means “in time  $O(n^k)$  for some  $k \in \mathbb{N}$ .”
  - There's a \$1,000,000 bounty on this problem  
- we'll see why in Week 10. 😊

# Recap for Today

- A ***graph*** is a structure for representing items that may be linked together. ***Digraphs*** represent that same idea, but with a directionality on the links.
- Graphs can't have ***self-loops***; digraphs can.
- ***Vertex covers*** and ***independent sets*** are useful tools for modeling problems with graphs.
- The complement of a vertex cover is an independent set, and vice-versa.

# Next Time

- ***Paths and Trails***
  - Walking from one point to another.
- ***Local Area Networks***
  - The building blocks of the internet.
- ***Trees***
  - A fundamental class of graphs.